

TECHNICAL MANUAL
OPERATOR'S AND UNIT
MAINTENANCE MANUAL
FOR
20,000 GALLON
COLLAPSIBLE FABRIC TANK
NSN 5430-01-106-9678 AND
NSN 5430-01-406-0507
AND
50,000 GALLON
COLLAPSIBLE FABRIC TANK
NSN 5430-01-406-6323

HOW TO USE THIS MANUAL	III	
EQUIPMENT DESCRIPTION	1-3	
OPERATION UNDER USUAL CONDITIONS	2-6	
OPERATOR MAINTENANCE INSTRUCTIONS	3-1	
UNIT MAINTENANCE PROCEDURES	4-1	
ALPHABETICAL INDEX	I-1	

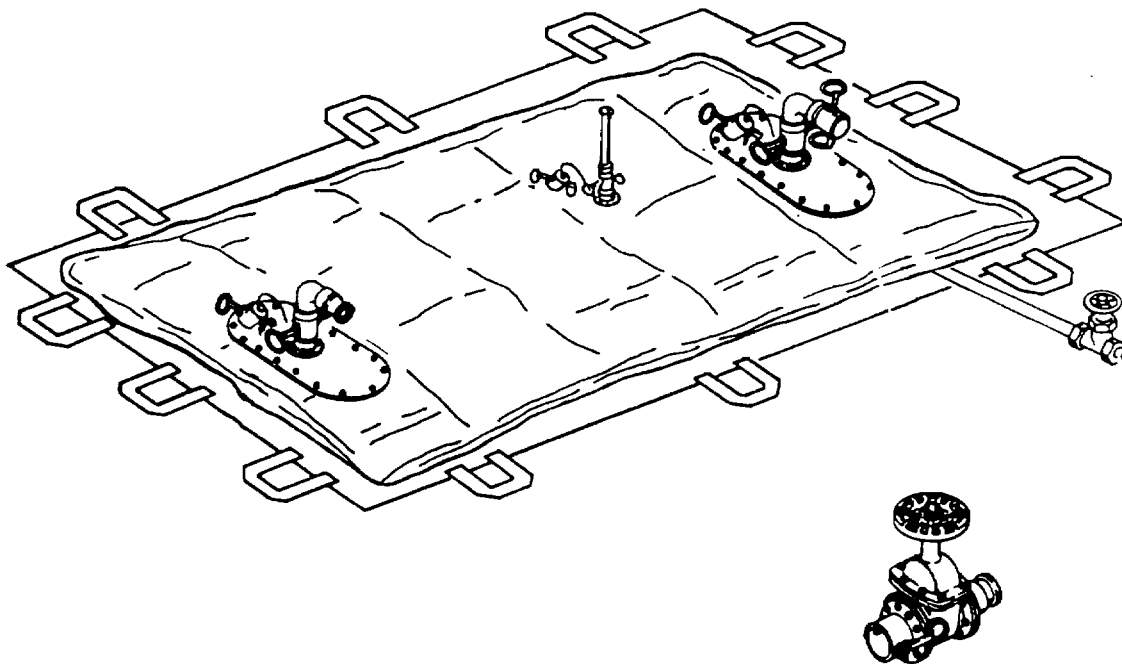

DISTRIBUTION STATEMENT A: Approved for public release; distribution is unlimited.

* This manual supersedes TM 5-5430-226-12, dated 11 April 1990, including all changes.

HEADQUARTERS, DEPARTMENT OF THE ARMY

22 JANUARY 1997

WARNINGS

To prevent injury to personnel and damage to the water tank, do not use air pressure in excess of 30 psi when drying tank. Do not over pressurize water tank.

Do not open coupling locking arms when water is stored in tank.

For artificial respiration, refer to FM21-11.

a/(b Blank)

**Operator's and Unit Maintenance Manual
for
20,000 Gallon Collapsible Fabric Tank
NSN 5430-01-106-9678 and NSN 5430-01-406-0507
and
50,000 Gallon Collapsible Fabric Tank
NSN 5430-01406-6323**

REPORTING ERRORS AND RECOMMENDING IMPROVEMENTS

You can help improve this manual. If you find any mistakes, or if you know of a way to improve these procedures, please let us know. Mail your letter or DA Form 2028 (Recommended Changes to Publications and Blank Forms), or DA Form 2028-2 located in the back of this manual directly to: Commander, US Army Aviation and Troop Command, ATTN: AMSAT-I-MP, 4300 Goodfellow Blvd., St. Louis, MO 63120-1798. You may also submit your recommended changes by E-mail directly to <mpmt%avma28@st-louis-emh7.army.mil>. A reply will be furnished directly to you. Instructions for sending an electronic 2028 may be found at the back of this manual immediately preceding the hard copy 2028.

Distribution Statement A: Approved for public release; distribution is unlimited.

TABLE OF CONTENTS

	PAGE
HOW TO USE THIS MANUAL.....	iii
CHAPTER 1 INTRODUCTION	
Section I General Information	1-1
Section II Equipment Description.....	1-3
Section III Technical Principles of Operation	1-9
CHAPTER 2 OPERATING INSTRUCTIONS	
Section I Description and Use of Operator's Controls.....	2-1
Section II Operator Preventive Maintenance Checks and Services	2-2
Section III Operation Under Usual Conditions.....	2-6
Section IV Operation Under Unusual Conditions.....	2-18
CHAPTER 3 OPERATOR MAINTENANCE	
Section I Lubrication Instructions	3-1
Section II Operator Troubleshooting Procedures	3-1
Section III Operator Maintenance Procedures	3-3

* This manual supersedes TM 5-5430-226-12, dated 11 April 1990, including all changes.

TABLE OF CONTENTS - cont.

	PAGE
CHAPTER 4	UNIT MAINTENANCE
Section I	Repair Parts, Special Tools; Test, Measurement and Diagnostic Equipment (TMDE); and Support Equipment 4-1
Section II	Service Upon Receipt 4-1
Section III	Unit Preventive Maintenance Checks and Services 4-3
Section IV	Unit Troubleshooting Procedures 4-5
Section V	Unit Maintenance Procedures 4-8
Section VI	Preparation for Storage or Shipment 4-26
APPENDIX A	References A-1
APPENDIX B	Maintenance Allocation Chart B-1
APPENDIX C	Components of End Item and Basic Issue Items List C-1
APPENDIX D	Expendable/Durable Supplies and Materials List D-1
APPENDIX E	Additional Authorization List (AAL) (Not Applicable) E-1
ALPHABETICAL INDEX	Index 1

HOW TO USE THIS MANUAL

Be sure to read all Warnings before using your equipment.

This manual contains operating instructions and Operator and Unit Maintenance instructions for the 20,000 gallon and 50,000 gallon water tanks.

- Chapter 1 - Introduces you to the equipment and gives you information such as weight, height length, generally used abbreviations, cross reference information and principles of operation. The chapter is preceded by a full page illustration of the equipment.

- Chapter 2 - Provides information necessary to identify and use the equipment's operating controls. Operating procedures tell you how to use the equipment in both usual and unusual weather conditions. In addition, preventive maintenance instructions provide information needed to inspect and service the 20,000 gallon and 50,000 gallon water tanks.

- Chapter 3 - Provides operator maintenance instructions for troubleshooting equipment malfunctions and performing emergency repairs.

- Chapter 4 - Provides unit maintenance instructions including service upon receipt, preventive maintenance and troubleshooting information; detailed maintenance and repair procedures for the Unit Maintenance repairer and storage and shipment instructions.

- Appendix A gives you a list of frequently used forms and publications.

- Appendix B is the Maintenance Allocation Chart (MAC). It identifies the type maintenance authorized for each maintenance organization.

- Appendix C describes components that make up the end item and are shipped with the basic equipment. It also lists components that are not mounted on the equipment, but are required to make the system functional. All components in the Components of End Item and Basic Issue Items Lists are illustrated for easy identification.

- Appendix D provides you with information about expendable/durable supplies such as sealant, paint, lubricants, etc. that you will need when performing maintenance.

- Appendix E lists additional equipment authorized for your unit for use with the water tank, but are not supplied as part of system. This equipment list may include fire extinguishers, buckets, protective clothing etc.

- The Alphabetical Index is the last item in the TM. You will find it useful in locating page numbers about specific information or procedures.

Becoming familiar with this manual will enable you to operate and maintain the equipment in good working order.

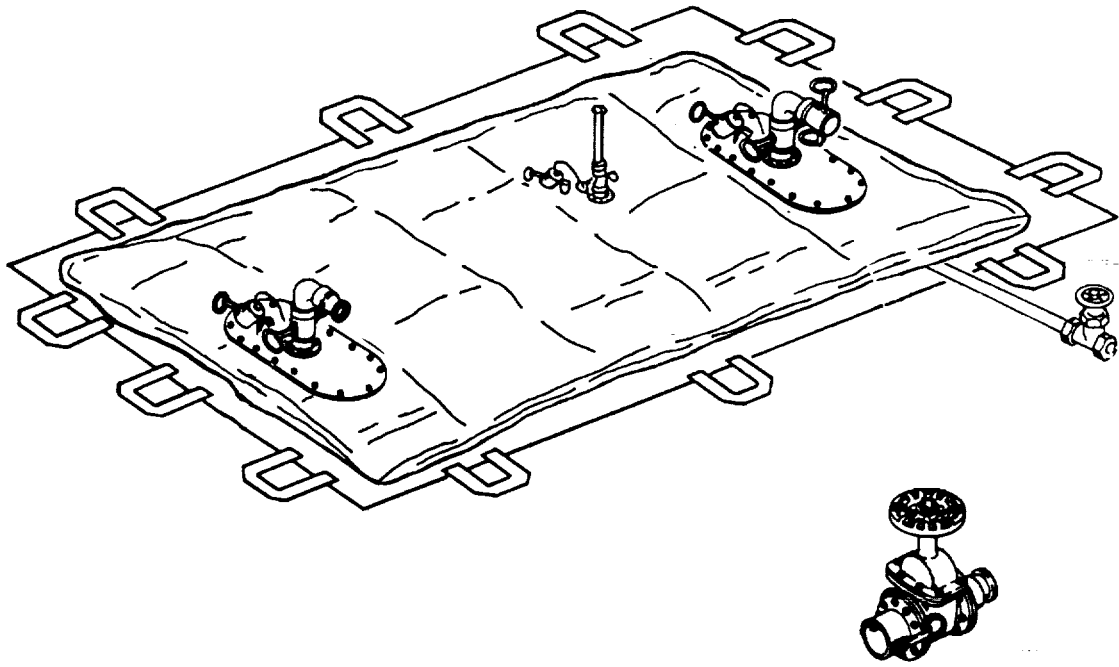

CHAPTER 1

INTRODUCTION

- Section I. General Information
- Section II. Equipment Description
- Section II. Principles of Operation

Section I. GENERAL INFORMATION

	Page
Scope	1-1
Hand Receipt Manuals	1-1
Maintenance Forms and Records	1-1
Reporting Equipment Improvement Recommendations (EIR's)	1-1
Destruction of Army Materiel to Prevent Enemy Use	1-2
Preparation for Storage or Shipment	1-2
List of Abbreviations	1-2

1-1. SCOPE.

- a. Type of Manual. This is an Operator's and Unit Maintenance manual for use with the 20K and 50K Gallon Collapsible Fabric Tanks. It provides instructions for operating and maintaining the equipment.
- b. Model Number and Equipment Name. The official equipment nomenclatures are Tank, Fabric, Collapsible, 20,000 Gallon, Drinking Water, specification part number M53029-20, and Tank, Fabric, Collapsible, 50,000 Gallon, Drinking Water, specification part number M53029-50.
- c. Purpose of Equipment. The 20K and 50K Gallon Collapsible Fabric Tanks (Drinking Water) are part of a water distribution system and are used to store and distribute potable water throughout the system.

1-2. MAINTENANCE FORMS AND RECORDS.

Department of the Army forms and procedures used for equipment maintenance will be those prescribed by DA PAM 738-750, The Army Maintenance Management System (TAM MS).

1-3. HAND RECEIPT MANUALS.

No hand receipt manual is available for this equipment.

1-4. DESTRUCTION OF ARMY MATERIEL TO PREVENT ENEMY USE.

For procedures and materials used to destroy Army materiel to prevent enemy use, Refer to TM750-244-3.

1-5. REPORTING EQUIPMENT IMPROVEMENT RECOMMENDATIONS (EIR's).

If your 20K or 50K Gallon Collapsible Fabric Tank needs improvement, let us know. Send us an EIR. You the user, are the only one who can tell us what you don't like about your equipment. Let us know why you don't like the design or performance. Put it on an SF 368 (Quality Deficiency Report). Mail it to us at Commander US Army Aviation and Troop Command, ATTN: AMSAT-I-MDO, 4300 Goodfellow Blvd., St Louis, MO. 63120-1798.

1-6. PREPARATION FOR STORAGE OR SHIPMENT.

a. Placement of equipment in administrative storage should be for short periods of time when a shortage of maintenance effort exists. Items should be in mission readiness within 24 hours or within the time factors as determined by the directing authority. During the storage period, appropriate maintenance records will be kept.

b. Before placing equipment in administrative storage, current maintenance services and Equipment Serviceable Criteria (ECS) evaluations should be completed, shortcomings and deficiencies should be corrected, and all Modification Work Orders (MWO's) should be applied.

c. Storage site selection. Inside storage is preferred for items selected for administrative storage. If inside storage is not available, trucks, vans, conex containers and other containers may be use.

d. For additional instructions on preparation for storage or shipment, refer to TM 740-90-1.

1-7. LISTOFABBREVIATIONS.

K

Kilo (Thousand)

Section II. EQUIPMENT DESCRIPTION

	Page
Equipment Characteristics, Capabilities, and Features	1-3
Difference Between Models	1-3
Location and Description of Major Components.....	1-4
Equipment Data	1-6

1-8. EQUIPMENT CHARACTERISTICS, CAPABILITIES, AND FEATURES.

a. Characteristics.

- (1) Portable. Tank rolls up to aid transportation.
- (2) Handles aid positioning and movement of the empty tank. The 20K tank has 12 handles and the 50K tank has 32 handles.
- (3) Water tank is supplied with all hardware required to connect tank with a water distribution system.
- (4) Quick disconnect couplings and fittings allow for rapid connection of system water hoses.

b. Capabilities and Features.

- (1) Capable of storing 20,000 or 50,000 gallons of potable water.
- (2) The self-erecting, pillow-shaped water tank is provided with a safety vent to prevent overfilling.
- (3) A separate nylon coated fabric ground cloth protects tank bottom from punctures.
- (4) Easily and quickly setup in the field.

1-9. DIFFERENCES BETWEEN MODELS.

- a. The two 20K models are similar except for minor variations in size and weight, and in configuration of the vent pipe. Amfuel models use a vent pipe with a welded base; the Bell-Avon model uses a cam-lock fitting.
- b. The Amfuel 50K model differs in size, capacity, and weight from both 20K models. It uses the same vent pipe assembly as the Amfuel 20K.
- c. The drain hose assembly and the valve are the same for both Amfuel models, but differ from that used on the Bell-Avon 20K.
- d. Both 20K models have 12 handles for movement of the tank. The 50K has 32 handles.

1-10. LOCATION AND DESCRIPTION OF MAJOR COMPONENTS.

The 20K and 50K Gallon Collapsible Fabric Tanks are supplied with all major components necessary to make the tanks operational. For the purpose of this manual, the 20K and 50K Gallon Collapsible Fabric Tanks will be addressed as kits comprised of the following major assemblies and components.

a. Tank. The collapsible water tank (4) is used to store potable water. Openings in the top of the tank allow connection of the vent, filler/discharge, and drain fittings. Handles (11) along the tank perimeter aid unfolding, positioning, and folding of the tank.

b. Fitting Assemblies.

- Drain Fitting Assembly. A drain fitting (6) consisting of a low profile adapter and plug is mounted on the bottom surface, toward one end of the tank. When the plug is removed, the (drain) hose assembly (5) can be connected.

- Vent Fitting Assembly. The vent fitting (2) connects to the top of the collapsible water tank and prevents damage caused by over pressurization. Venting of tank pressure is automatic and no operator control is required. A protective dust cap is provided to prevent entry of contaminants when tank is not in use.

- Filler/Discharge Assemblies. A filler assembly (3) and discharge assembly (1) are located on top of the collapsible water tank. Both assemblies are supplied with a 4-inch 90° elbow for use in connecting the tank to water distribution system hoses. A protective dust cap and plug are provided to prevent entry of contaminants when tank is not in use.

c. Accessories.

- Hose Assembly (Drain). The hose assembly (5) is comprised of an 8-foot section of hose with a hand operated gate or ball valve attached to one end. The hose is connected to the tank drain fitting during installation and allows operator control of tank draining.

- 4-inch Gate Valve. The 4-inch gate valve (8) allows operator control of water inlet or discharge. The valve may be connected in either the system fill or discharge hoses, or connected directly to the filler discharge fitting assemblies.

d. Ground Cloth. The ground cloth (7) provides protection for the water tank bottom surface. Fourteen handles aid positioning and installation of the cloth.

e. Repair Kit.

- Sealing Clamps and Plugs (10). Used to make temporary repairs to the water tank fabric.

- Gaskets and o-rings (9). Used to make repairs to cam-lock couplings, fitting assemblies and 4-inch gate valve. These parts are packaged as spare parts with water tank system.

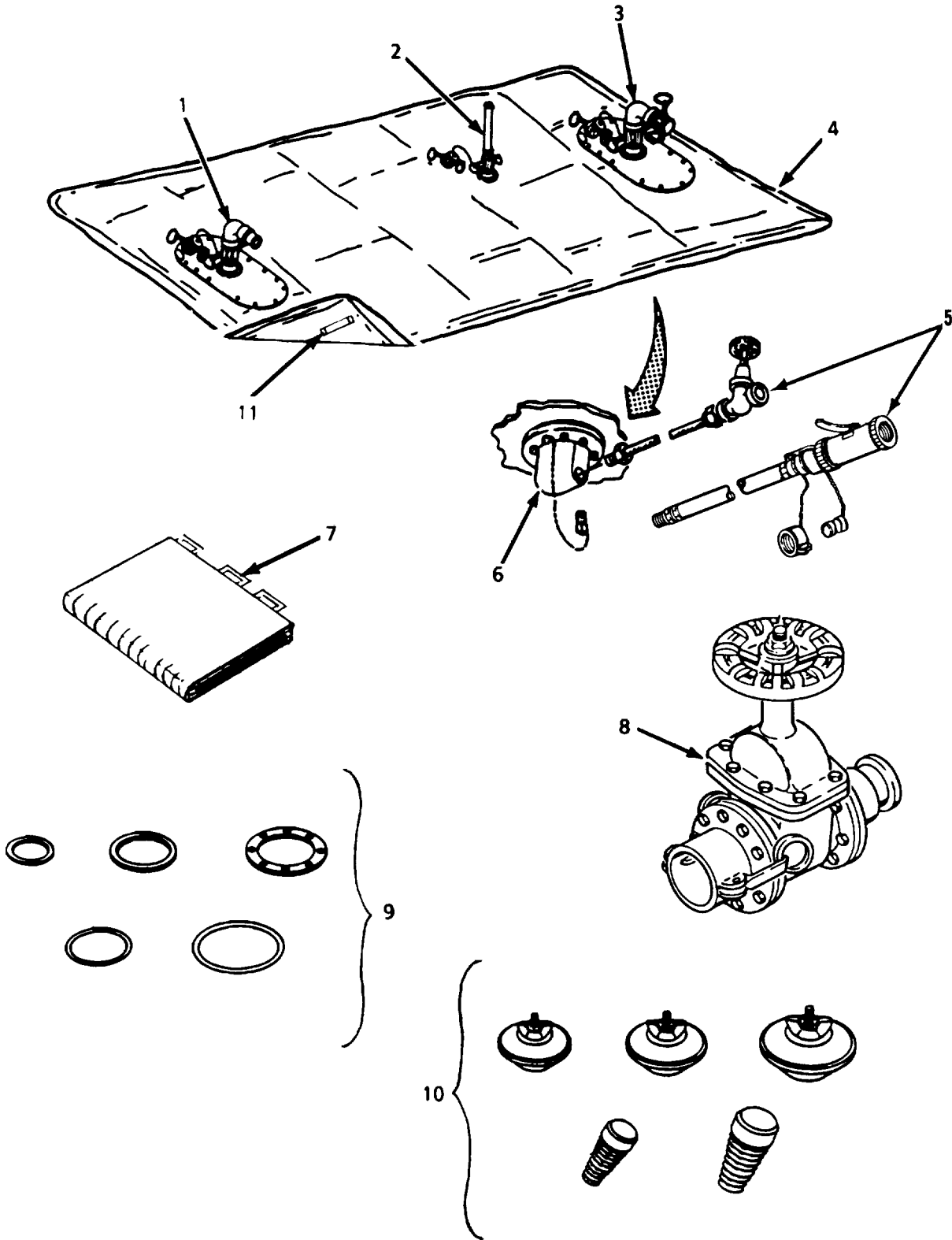

1-11. EQUIPMENT DATA (Refer to Table 1-1).

Table 1-1. Equipment Data

20K GALLON FABRIC COLLAPSIBLE TANK (BELL-AVON MODEL ETQ)

Collapsible Tank:

Manufacturer	Bell-Avon
Model	20,000 Gallons (75.71 Kiloliters).
Weight(Empty)	400Pounds (181.4kg).
Length (Full).....	26.5 Feet (8.08 Meters).
Width (Full)	22.5 Feet (686 Meters)
Height (Full to maximum capacity)	5 Feet, 6 Inches. (1 68 Meters)
Operating Temperature Range	-25°Fto + 125°F (-31°C to +51.6°C).

Fitting Assemblies:

Drain Fitting

Body.....	Cast aluminum.
Thread size	1./2-inch NPT.

Vent Fitting

Relief Pressure.....	3 inches of water
Couplings	Cam-lock quick disconnect
Size.....	2-inch

Fill/Discharge Fittings

Elbow Fittings.....	Filler- Female to Female; Discharge - Female to Male.
Couplings	Cam-lock Quick Disconnect
Size.....	4-inch

Accessories:

Hose Assembly (Drain)

Hose.....	Noncollapsible, 3/4-inch X 8-feet, 1/2- inch threaded male fittings.
Gate Valve (Drain)	Wheel operated, 1/2-inch rising stem gate valve.
4-inch Gate Valve.....	Wheel operated, 4-inch with cam-lock couplings

Table 1-1. Equipment Data - cont.

20K GALLON COLLAPSIBLE TANK (AMFUEL MODEL FLP)

Collapsible Tank:

Manufacturer	Amfuel
Model	20,000 Gallons (75.71 Kiloliters)
Weight (Empty)	450 Pounds (204 kg)
Length (Full)	28.5 Feet (8.69 Meters)
Width (Full)	24.3 Feet (7.42 Meters)
Height (Full to maximum capacity)	5.7 Feet (1.74 Meters)
Operating Temperature Range	-25°F to +125°F (-31°C to +51.6°C)

Fitting Assemblies:

Drain Fitting	
Body	Cast aluminum
Thread size	2-inch NPT
Vent Fitting	
Relief Pressure	3 inches of water
Size	2-inch
Fill/Discharge Fittings	
Elbow Fittings	Filler - Female to Female
.....	Discharge - Female to Male
Couplings	Cam-lock Quick Disconnect
Size	4-inch

Accessories:

Hose Assembly (Drain)	
Hose	Noncollapsible, 2 inches x 8 feet, 2-inch threaded male fittings and banded
Drain Valve	Handle operated, 2-inch ball valve, with cam-lock coupling
4-inch Gate Valve	Wheel operated, 4-inch with cam-lock couplings

50K GALLON COLLAPSIBLE TANK (AMFUEL MODEL FLQ)

Collapsible Tank:

Manufacturer	Amfuel
Model	50,000 Gallons (189.3 Kiloliters)
Weight (Empty)	920 Pounds (417.2 kg)
Length (Full)	25.5 Feet (7.77 Meters)
Width (Full)	65.5 Feet (20.0 Meters)
Height (Full to maximum capacity)	5.7 Feet (1.74 Meters)
Operating Temperature Range	-25°F to +125°F (-31°C to +51.6°C)

Table 1-1. Equipment Data - cont.

Fitting Assemblies:

Drain Fitting	
Body	Cast aluminum
Thread size	2-inch NPT
Vent Fitting	
Relief Pressure	3 inches of water
Size.....	2-inch
Fill/Discharge Fittings	
Elbow Fittings	Filler - Female to Female Discharge - Female to Male
Couplings	Cam-lock Quick Disconnect
Size.....	4-inch

Accessories:

Hose Assembly (Drain)	
Hose	Noncollapsible, 2 inches x 8 feet, 2-inch threaded male fittings and banded
Drain Valve	Handle operated, 2-inch ball valve, with cam-lock coupling
4-inch Gate Valve	Wheel operated, 4-inch with cam-lock couplings

Section III. TECHNICAL PRINCIPLES OF OPERATION

	Page
Principles of Operation.....	1-9
Safety, Care and Handling	1-9

1-13. PRINCIPLES OF OPERATION.

a. General. The 20K and 50K collapsible water tanks described in this manual are functional components of a water distribution system. Any number of water tanks may be connected to the system, depending on operational requirements.

b. Filling. Potable water to fill the water tank is supplied by a water distribution system. The system water pumps draw water from the source (tanker truck, pipeline, or purification equipment) and pump it into the water tank through the filler assembly. Control of water flow between the supply pumps and the water tank is accomplished by opening or closing gate valves within the system supply circuit. As the water tank fills, the tank will enlarge. When the tank is full, or no more water is needed, supply circuit gate valves are then closed. Excessive pressures caused by overfilling the tank are relieved by the vent fitting assembly. The vent unseats when internal water pressure exceeds 0.10 psi (0.00680 Atmospheres). The 4-inch gate valve supplied with the tank may be installed on the filler elbow to control water tank fill rate.

c. Discharge. When needed, water is drawn from the tank by system suction pumps, and distributed through a network of valves and hoses to the field installed facilities. As water is drawn from the tank, tank will flatten. Water flow between the system discharge pumps and the water tank is controlled by system gate valves. The 4-inch gate valve supplied with the tank may be installed on the discharge elbow to control water tank discharge rate. When the tank is empty, or no more water is needed, the down stream system discharge gate valves are then closed. Venting of the tank during discharge is not required.

d. Draining. A hand operated valve connected to the tank drain fitting controls water flow from the tank. This valve allows a restricted flow of water from the tank for sampling or complete drainage. When preparing the tank for movement, the system suction pumps will draw most of the water from the tank. To ensure complete drainage, the hand valve is opened.

1-14. SAFETY, CARE, AND HANDLING.

Observe all Warnings, Cautions and Notes in this manual. This equipment can be dangerous or may be damaged if these instructions are not followed.

CHAPTER 2

OPERATING INSTRUCTIONS

- Section I. Description and Use of Operator's Controls
- Section II. Operator's Preventive Maintenance Checks and Services (PMCS)
- Section III. Operation Under Usual Conditions
- Section IV. Operation Under Unusual Conditions

Section I. DESCRIPTION AND USE OF OPERATOR'S CONTROLS

	Page
Introduction	2-1
Control Valves	2-1

2-1. INTRODUCTION.

This section provides information needed by the operator to locate, identify, and use the controls required to operate the 20K and 50K Gallon Collapsible Fabric Tanks. Only two operator controls are used on the water tanks.

2-2. CONTROL VALVES.

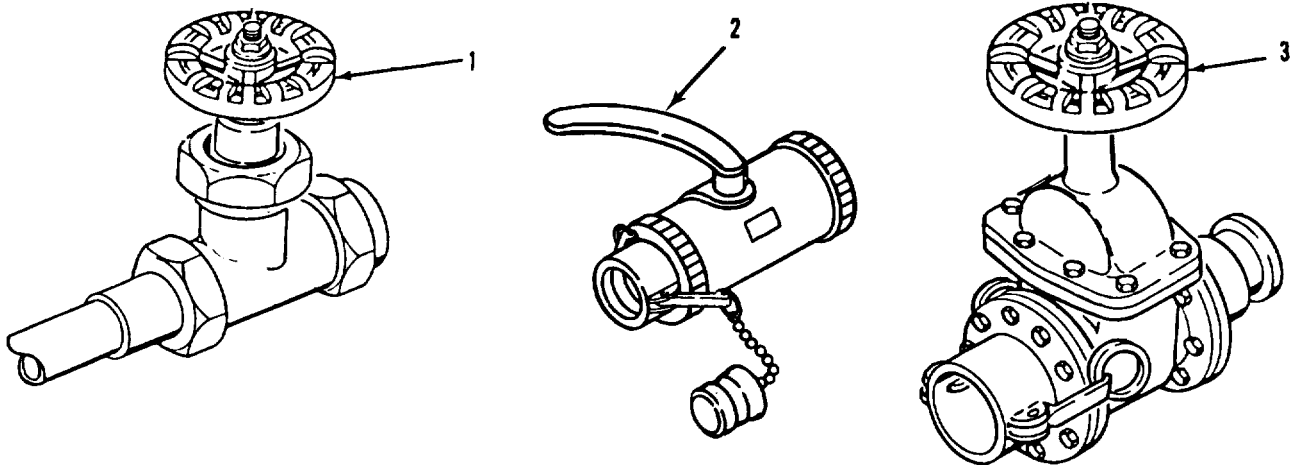

Key	Control	Function
1	Handwheel - 1/2-inch hand operated drain valve.	Starts and stops water flow from drain hose (Bell-Avon Model ETQ).
2	Lever - 2-inch hand operated drain valve.	Starts and stops water flow from drain hose (Amfuel Models FLP, FLQ).
3	Handwheel - 4-inch gate valve.	Controls water flow to or from water tank.

Section II. OPERATOR PREVENTIVE MAINTENANCE CHECKS AND SERVICES (PMCS)

	Page
Introduction.....	2-2
Operator Preventive Maintenance Checks and Services.....	2-3

2-3. INTRODUCTION

a. General.

Your Preventive Maintenance Checks and Services table lists the inspections and care of your equipment required to keep it in good operating condition. The interval column of your PMCS table tells you when to do a certain check or service. The procedures column of the table tells you how to do the required task. Carefully follow these instructions. If your equipment does not perform as required, refer to Chapter 3 Troubleshooting Procedures.

- (1) Before You Operate. (Always keep in mind the CAUTIONS and WARNINGS. Perform your before (B) PMCS.
- (2) While You Operate. Always keep in mind the CAUTIONS and WARNINGS. Perform your during (D) PMCS.
- (3) After You Operate. Be sure to perform your after (A) PMCS.
- (4) If Your Equipment Fails to Operate. If your equipment does not perform as required, refer to Chapter 3 under Troubleshooting for possible problems. Report any malfunctions or failures on DA Form 2404, or refer to DA PAM 738-750.

b. PMCS Procedures.

- (1) Purpose of PMCS. Your Preventive Maintenance Checks and Services list the inspections and servicing requirements necessary to keep the equipment in good operating condition.
- (2) Item Number Column. Checks and services are numbered in chronological order regardless of interval. This column is used as a source of item number-for the "TM Number" column on DA Form 2404, Equipment Inspection and Maintenance Worksheet, in recording results of PMCS.
- (3) Interval Columns. The interval columns tell you when to do a certain check or service: before, during, or after operation. Sometimes a dot may be placed in more than one interval column which means you should do the check or service at each of the intervals.
- (4) Item To Be Inspected Column. This column lists the common name of the item to be inspected such as "Drain Assembly".

(5) Procedures Column. This column tells you how to do the required checks or services. Carefully follow these instructions. If you do not have the tools, or if the procedures tell you to, have unit maintenance do the work.

(6) Equipment Is Not Ready/Available If Column. This column tells you when and why your equipment cannot be used.

NOTE

The terms ready/available and mission capable refer to the same status: equipment is on hand and is able to perform its combat missions. (See DA PAM 738-750).

c. Leakage Definitions.

- Class I** Seepage of fluid (as indicated by wetness or discoloration) not great enough to form drips.
- Class II** Leakage of fluid great enough to form drops, but not enough to cause drops to drip from item being checked/inspected.
- Class III** Leakage of fluid great enough to form drops that fall from the item being checked/inspected.

2-4. OPERATOR PREVENTIVE MAINTENANCE CHECKS AND SERVICES

CAUTION

Equipment operation is allowable with minor leakages (CLASS I or II). Of course, you must consider the fluid capacity in the item/system being checked/inspected. When in doubt, notify your supervisor.

Table 2-1. Operator Preventive Maintenance Checks and Services.

Item No.	INTERVAL			Item To Be Inspected	Procedures Check for and have repaired or adjusted as necessary	Equipment is not Ready/Available If:
	B	D	A			
1	•	•	•	<u>Tank, Fabric Collapsible, 20,000 Gallon or 50,000 Gallon (End item)</u>	Inspect entire unit for physical damage. Check that all major components are present.	Major components are missing.
2	•		•	<u>Water Tank</u>	a. Inspect tank for tears, punctures, and loose seams. b. Inspect for loose or missing bolts where fittings connect to tank. Tighten loose bolts. c. Inspect for damaged or missing dust covers. Check covers for damaged or missing gasket.	Tank is torn, punctured or seam(s) is loose. Bolts are missing. Dust cover missing.

Table 2-1. Operator Preventive Maintenance Checks and Services - cont.

Item No.	INTERVAL			Item To Be Inspected	Procedures Check for and have repaired or adjusted as necessary	Equipment is not Ready/Available If:
	B - Before Operation	D - During Operation	A - After Operation			
3	•	•	•	<p><u>Water Tank (cont)</u></p> <p><u>Fitting Assemblies</u> Vent Fitting Assembly</p>	<p>d. Inspect for leaks in tank fabric and around tank fitting connections. If tank leaks, install clamp patch or plug from repair kit.</p> <p>a. For models with a vent pipe having a cam-lock coupling, inspect the coupling for cracks and/or damaged locking arms.</p> <p>b. For models with a vent pipe having a threaded coupling, inspect for damaged or missing coupling gasket.</p> <p>c. Lift vent cap and check for free movement. Inspect for cracks, bends, and bent or broken pivot pin.</p> <p>d. Inspect vent pipe for cracks or damage.</p> <p>e. For models with a vent pipe having a cam-lock coupling, inspect vent coupling for leaks.</p>	<p>Tank leaks at fitting connection. Leak cannot be stopped by clamp patch or plug.</p> <p>Coupling is cracked. Locking arms damaged.</p> <p>Coupling gasket is damaged or missing.</p> <p>Vent cap binds or is damaged.</p> <p>Vent is cracked or damaged.</p> <p>Class III leak at coupling.</p>
			•			
			•			
			•			
			•			
4	•	•	•	<p>Fill/Discharge Assemblies</p>	<p>a. Inspect elbow couplings for cracks. Inspect locking arms for damage.</p> <p>b. Inspect for damaged or missing coupling gaskets.</p> <p>c. Inspect for leaks at elbow couplings.</p>	<p>Coupling is cracked. Locking arms damaged.</p> <p>Coupling gasket is damaged or missing.</p> <p>Class III leak at elbow.</p>
			•			
			•			
5	•	•	•	<p>Drain Assembly</p>	<p>a. Inspect drain body for cracks and damage.</p> <p>b. Check for loose or missing drain plug.</p>	<p>Drain body cracked.</p> <p>Drain plug missing.</p>
			•			

Table 2-1. Operator Preventive Maintenance Checks and Services - cont.

Item No.	INTERVAL			Item To Be Inspected	Procedures Check for and have repaired or adjusted as necessary	Equipment is not Ready/Available If:
	B	D	A			
6	•		•	<u>Accessories</u> Hose Assembly	Inspect hose for punctures, tears, and damaged fittings.	Hose punctured. Fittings damaged.
7	•	•	•	Drain Valve	a. Open and close valve. Valve stem should turn freely. b. Inspect valve stem for leaks. c. On tanks manufactured by Amfuel Company, inspect cam-lock couplings for cracks. Inspect locking arms for damage. d. On tanks manufactured by Amfuel Company, inspect for damaged or missing coupling gaskets. e. On tanks manufactured by Amfuel Company, inspect for leaks at couplings.	Valve stem sticks or binds. Valve stem leaks. Coupling is cracked or damaged.
	•		•			Gaskets leak.
		•				Couplings leak.
8	•		•	4-inch Gate Valve	a. Inspect for loose or missing valve handle. b. Open and close valve. Valve stem sticks or binds. Valve stem should turn freely. c. Check for loose or missing bolts and nuts. d. Inspect valve stem, bonnet and flange gaskets for leaks.	Valve handle missing. Valve stem Hardware missing. Gaskets leak.
9	•		•	Ground Cloth	Inspect for tears.	Ground cloth excessively torn.
10	•		•	Repair Kit	Check for missing components. Compare packing list with components in kit.	Components of repair kit missing.

Section III. OPERATION UNDER USUAL CONDITIONS

	Page
Assembly and Preparation for Use	2-6
Decals and Instruction Plates	2-17
General	2-6
Initial Adjustment	2-6
Operation	2-10
Preparation for Movement	2-12
Unpacking	2-6

2-5. GENERAL.

The following procedures describe assembly, operation, and preparation of the 20K and 50K Gallon Collapsible Water Tanks.

2-6. UNPACKING.

If your water tank is supplied as part of the 40K Water Distribution System, the tank may be supplied in a reusable container.

2-7. INITIAL ADJUSTMENTS.

Inspect the equipment for damage incurred during shipment. Report any problems to your supervisor.

2-8. ASSEMBLY AND PREPARATION FOR USE.

- a. Site Selection.
 - (1) Site selected for installation should be level and large enough to contain the filled water tank. Site selection must also consider location within a water distribution system.
 - (2) Remove rocks, twigs, lumps of dirt, and debris that can puncture tank bottom.
- b. Unfolding.

NOTE

Two personnel are required to unfold ground cloth.

- (1) Remove ties that hold folded ground cloth together. Unfold ground cloth over installation site.

WARNING

Four personnel are required to position and unfold the 20K water tanks. The empty 20K water tank weighs about 450 pounds (204 kg). Five personnel are required to position and unfold the 50K water tank. The empty 50K water tank weighs about 920 pounds (417 kg).

NOTE

The water tank is folded toward the center.

- (2) Position folded tank in center of ground cloth.

2-8. ASSEMBLY AND PREPARATION FOR USE - cont.

- (3) Remove ties that hold folded tank together.
- (4) Unfold tank.
- (5) Make sure tank filler/discharge and vent openings are facing up.

NOTE

To aid in draining, position tank drain at lowest point of installation site.

- (6) Using handles, center tank over ground cloth. Position tank drain at low point in site.

c. Assembly.

- (1) Install drain hose assembly as follows:

- (a) Fold back water tank (2) and locate drain assembly (6).
- (b) Unscrew drain plug (7) from drain assembly (6).
- (c) Apply anti-seize tape (item 3, Appendix D) to threads of drain hose assembly (5).
- (d) Using wrench (Appendix C, Section II, item 3), connect end of drain hose assembly (5) to drain assembly (6).
- (e) Fold ground cloth (1) back over water tank (2). Dig a shallow, narrow trench from the drain assembly (6) to outer edge of tank. Trench must allow free drainage when tank is emptied and folded for repacking.

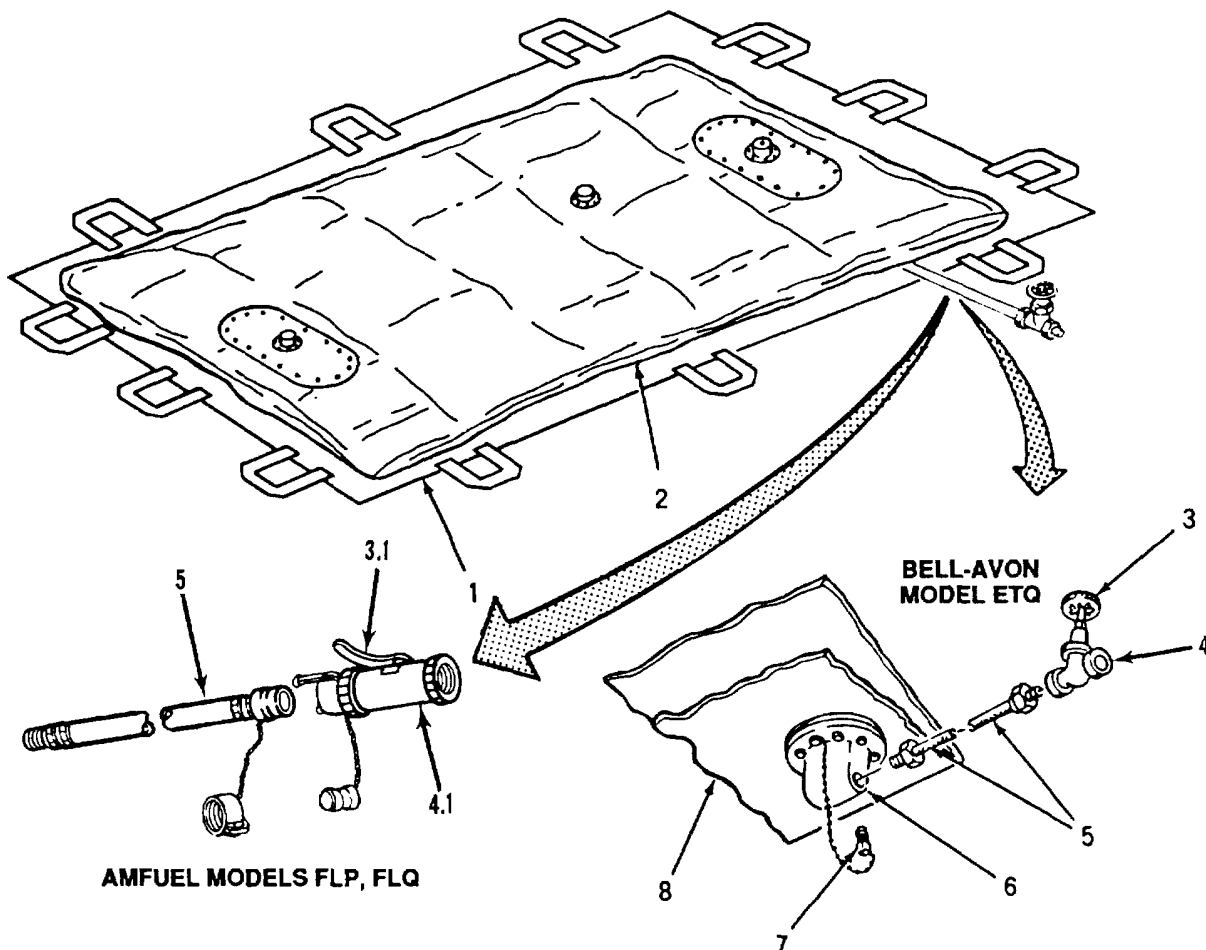

2-8. ASSEMBLY AND PREPARATION FOR USE - cont.

- (f) Lay ground cloth (1) flat and press into trench.
- (g) Position drain hose assembly (5) in trench. Make sure control valve (4 or 4.1) is positioned with handwheel (3) or lever (3.1) pointing up.
- (h) Lay water tank (2) flat and smooth out large wrinkles. Make sure drain hose assembly (5) extends beyond tank edge and control valve (4 or 4.1) is accessible.
- (i) Make sure control valve handwheel (3) or lever (3.1) is fully closed.

NOTE

Tanks manufactured by Bell-Avon have a vent pipe with a cam-lock fitting at the base (14 and 15). Step (2) describes how to prepare these vent pipes. Tanks manufactured by Amfuel have a vent pipe with a welded base (13.1). Step (3) describes how to prepare these vent pipes.

- (2) If the tank has a cam-lock fitting (15) at the base of the vent pipe (13), prepare the vent pipe as follows:
 - (a) Remove dust cap (16) from vent fitting (15) located in the center of the water tank (2).
 - (b) Position vent pipe (13) over vent fitting (15). Push down on vent pipe and pull locking arms (14) in toward coupling. Make sure coupling is securely connected.
- (3) If the tank has a vent pipe (13.1) welded to the base, prepare the vent pipe as follows:
 - (a) Remove threaded dust cap (14.1) from vent pipe (13.1) located in the center of water tank (2).
 - (b) Install gasket (15.1) and threaded relief valve (16.1) onto vent pipe (13.1) and tighten.

NOTE

Either tank opening can be used as filler or discharge port.

- (4) Install filler elbow (17) as follows:
 - (a) Remove dust cap (20) from filler fitting (19).
 - (b) Open locking arms (18) of filler elbow (17).
 - (c) Position elbow (17) coupling over filler fitting (19). Rotate elbow so that opening points toward closest edge of water tank (2). Push elbow down onto fitting and pull locking arms (18) in toward coupling. Make sure coupling is securely connected.
- (5) Install discharge elbow (9) as follows:
 - (a) Remove dust cap (12) from discharge fitting (11).
 - (b) Open locking arms (10) on discharge elbow (9) coupling.
 - (c) Position female end of discharge elbow (9) over discharge fitting (11). Rotate elbow so that opening points toward closest edge of tank (2). Push elbow down onto fitting and pull locking arms (10) in toward elbow. Make sure coupling is securely connected.

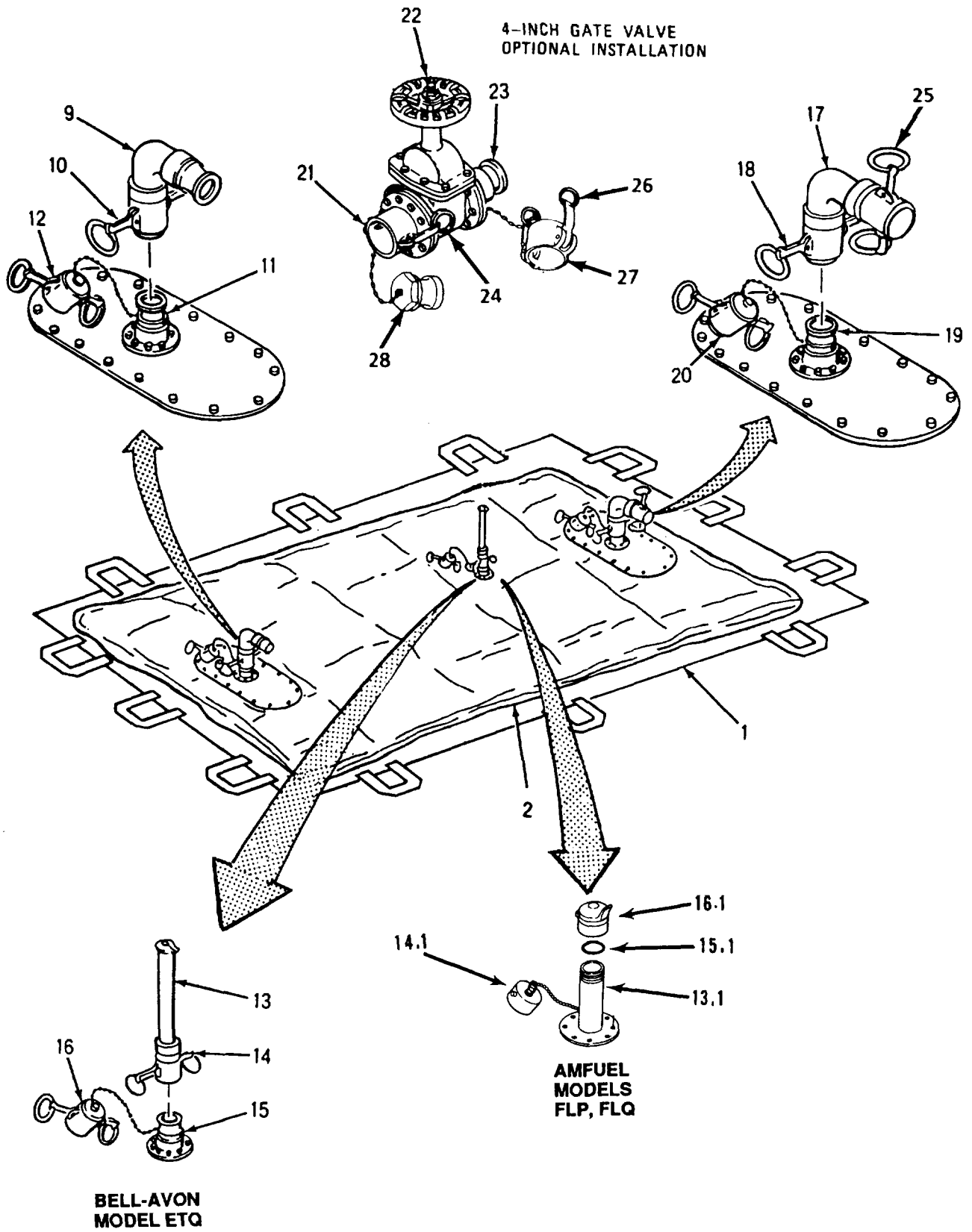

2-8. ASSEMBLY AND PREPARATION FOR USE - cont.

- (6) Install 4-inch gate valve (24). Installation of the 4-inch gate valve is optional. Your system operating requirements will determine if installation is necessary. If required, install the gate valve as follows:
 - (a) Open locking arms (21 and 26) and remove cap (27) and plug (28). To install gate valve in discharge line, open locking arms (21) on gate valve (24) coupling. Position female coupling of gate valve over discharge elbow (9). Push gate valve onto elbow and pull gate valve lock arms (21) in toward valve. Make sure coupling is securely connected.
 - (b) Open locking arms (21 and 26) and remove cap (27) and plug (28). To install gate valve (24) in filler line, position male coupling (23) in filler elbow (17). Push gate valve into elbow and pull locking arms (25) on filler elbow in toward coupling. Make sure coupling is securely connected.
 - (c) Close gate valve (24) by turning handwheel (22) fully clockwise.
- (7) Connect water tank to a water distribution system as follows:

NOTE

Refer to applicable water distribution systems manual for specific system installation requirements.

- (a) Connect system discharge hose to water tank filler elbow (17). Make sure coupling is securely connected.
 - (b) Connect system noncollapsible suction hose to water tank discharge elbow (9).
- (8) Ensure all couplings are securely connected.

2-9. OPERATION.

- a. General. The fill mode of operation fills the water tank and the discharge mode draws water from the tank. The fill and discharge modes can occur at the same time. Water is pumped to and drawn from the water tank by components of a water distribution system. Operator control of the water tank during all modes of operation is limited to the drain control and 4-inch gate valves.
- b. Fill Mode.
 - (1) Verify that drain control valve (4) is closed.
 - (2) Verify that vent assembly relief valve (29) is not stuck closed.
 - (3) If 4-inch gate valve (24) is installed on discharge elbow (9), close gate valve.
 - (4) If 4-inch gate valve (24) is installed on filler elbow (17), open gate valve.
 - (5) Close water system discharge circuit gate valve (refer to applicable system manual).
 - (6) Open water system fill circuit gate valve(s) (refer to applicable system manual).
 - (7) Start system fill circuit water pumps (refer to applicable system manual).
 - (8) Allow water to flow into tank until full, or required amount is received.
 - (9) If 4-inch gate valve (24) is installed on filler elbow (17), close gate valve.
 - (10) Close water system fill circuit gate valve(s) (refer to applicable system manual).

2-9. OPERATION - cont.

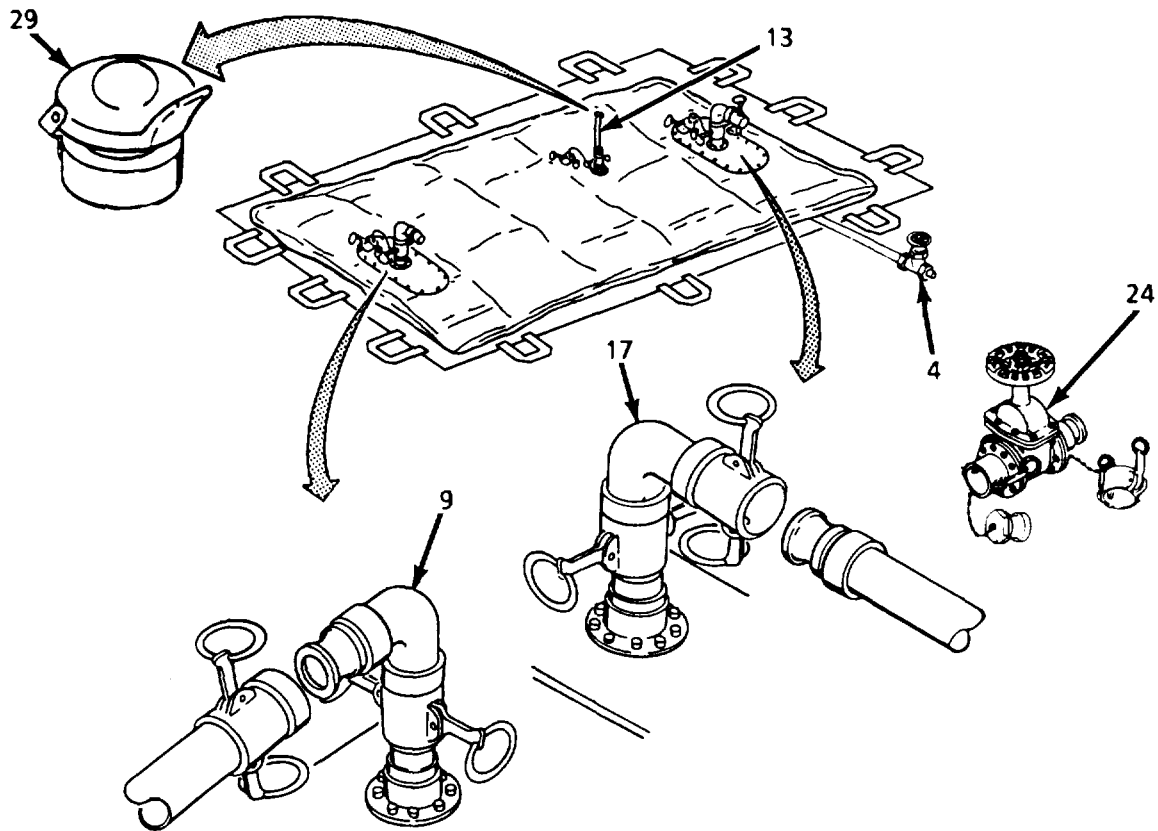
c. Discharge Mode.

- (1) Verify that drain control valve (4) is closed.
- (2) Verify that vent assembly relief valve (29) is not stuck closed.
- (3) If 4-inch gate valve (24) is installed on discharge elbow (9), open gate valve.
- (4) If 4-inch gate valve (24) is installed on filler elbow (17), close gate valve.
- (5) Open water system discharge circuit gate valve (refer to applicable system manual).
- (6) Close water system fill circuit gate valve(s) (refer to applicable system manual).
- (7) Start system discharge (suction) circuit water pumps (refer to applicable system manual).
- (8) Allow water to flow from tank until required amount is discharged.
- (9) If 4-inch gate valve (24) is installed on discharge elbow (9), close gate valve.
- (10) Close water system discharge (suction) circuit gate valve(s) (refer to applicable system manual).

2-10. PREPARATION FOR MOVEMENT.

- a. Disassembly.

CAUTION

To prevent damage to water tank, remove gravel, rocks, and debris from bottom of shoes before walking on tank fabric.

NOTE

Four personnel are required to handle a 20K water tank during draining and disassembly. Five personnel are required to handle a 50K water tank during draining and disassembly.

- (1) Open drain hose control valve (19 or 19.1).
- (2) Remove 4-inch gate (18) valve as follows:

NOTE

Use of the 4-inch gate valve is optional and may not have been used during operation. If installed, remove gate valve as follows:

- (a) If gate valve (18) was installed on filler elbow (9), pull locking arms (27) out from elbow coupling and disconnect gate valve. Turn handle (16) to open gate valve. Drain water from valve and allow to dry. Install dust cap (26) and plug (24). Close locking arms (15 and 25).
 - (b) If gate valve (18) was installed on discharge elbow (1), pull locking arms (15) out from gate valve coupling and disconnect gate valve (18). Turn handwheel (16) to open gate valve. Drain water from valve and allow to dry. Install cap (26) and plug (24). Close locking arms (15 and 25).
- (3) Disconnect system noncollapsible suction hose from water tank discharge elbow (1).
 - (4) Remove discharge elbow (1) as follows:
 - (a) Open lock arms (2) on discharge elbow (1) coupling.
 - (b) Disconnect discharge elbow (1) from water tank discharge fitting (3).
 - (c) Install dust cap (4) on discharge fitting (3). Close locking arms on dust cap.
 - (d) Drain water from elbow (1) and allow to dry.
 - (5) Disconnect system collapsible discharge hose from filler elbow (9).
 - (6) Remove filler elbow (9) as follows:
 - (a) Open locking arms (10) on filler elbow (9) coupling.
 - (b) Disconnect filler elbow (9) from water tank filler fitting (11).

- (c) Install dust cap (12) on filler fitting (11). Close locking arms on dust cap.
- (d) Drain water from elbow (9) and allow to dry.

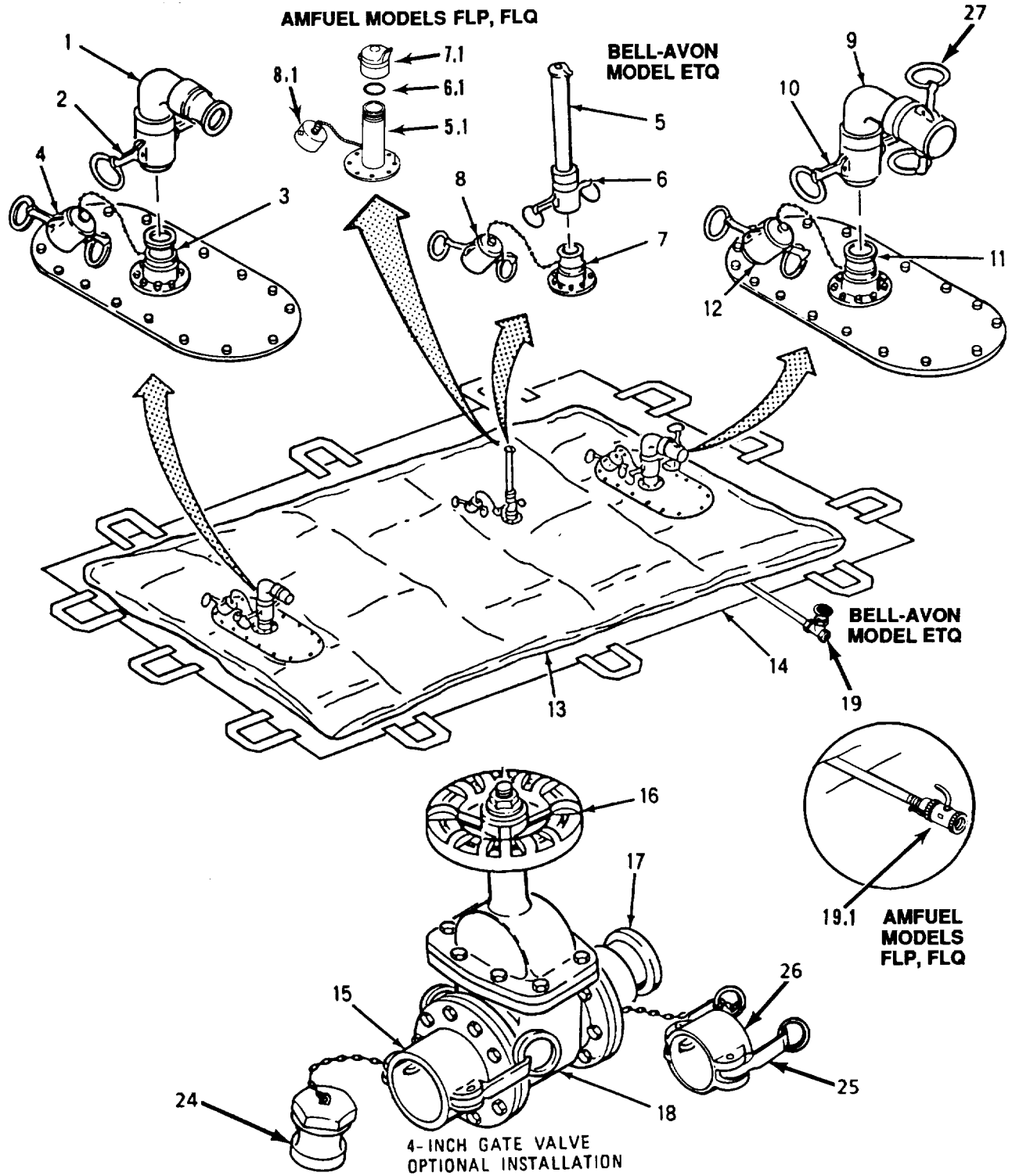

2-10. PREPARATION FOR MOVEMENT - cont.

NOTE

Tanks manufactured by Bell-Avon have a vent pipe with a cam-lock fitting at the base (7). Step (7) describes how to prepare these vent pipes. Tanks manufactured by Amfuel have a vent pipe with a welded base (5.1). Step (8) describes how to prepare these vent pipes.

(7) If tank has a vent pipe with a cam-lock fitting at the base (7), prepare the vent pipe as follows:

- (a) Open locking arms (6) on vent pipe coupling located in center of tank (13).
- (b) Remove vent pipe (5) from vent fitting (7).
- (c) Drain water from vent pipe (5) and allow to dry.
- (d) Install dust cap (8) on vent fitting (7). Close locking arms on dust cap.

(8) If tank has a vent pipe with a welded base (5.1), prepare the vent pipe as follows:

- (a) Remove threaded relief cap (7.1) and gasket (6.1) from vent pipe (5.1) located in center of water tank (13).

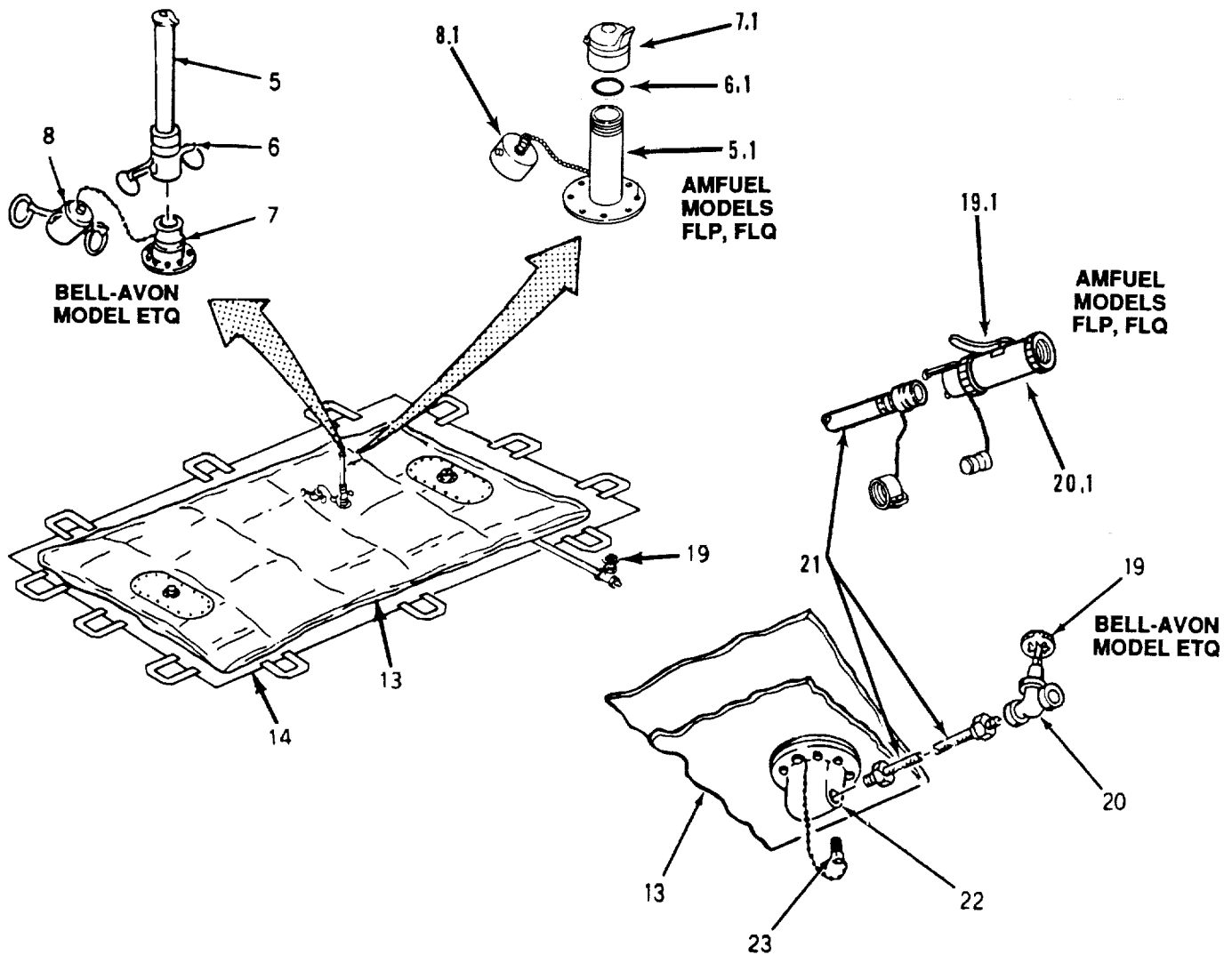

2-10. PREPARATION FOR MOVEMENT - cont.

- (b) Install threaded dust cap (8.1) on vent pipe (5.1) and tighten fully.
- (9) Roll water tank (13) edges in to center of tank while squeezing water toward drain fitting (23).
- (10) Lift tank edges as required to force remaining water toward drain fitting (23). Allow water to drain.
- (11) Remove drain hose assembly (21) as follows:
 - (a) Lift water tank (13) edge and locate drain fitting (22).
 - (b) Using wrench (Appendix C, Section III, item 3), disconnect drain hose assembly (21) from drain fitting (22).
 - (c) Install plug (23) in drain fitting (22).

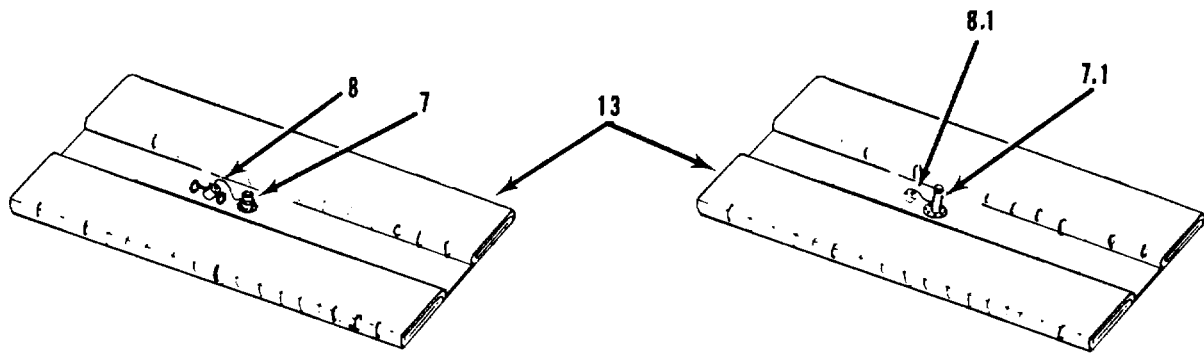
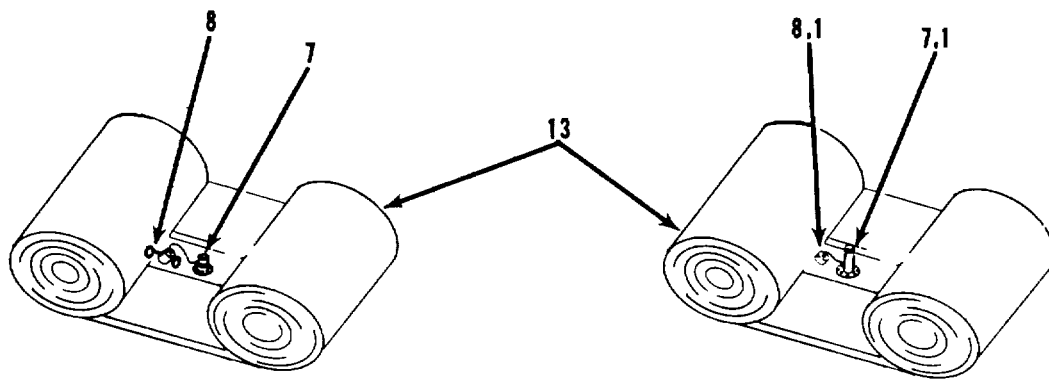
b. Folding.**FOLD SIDES TOWARD CENTER OF TANK****ROLL TANK ENDS TOWARD VENT FITTING**

2-10. PREPARATION FOR MOVEMENT - cont.b. Folding - cont.**NOTE**

Four personnel are required to fold a 20K tank and five personnel are required to fold a 50K tank. Push out trapped air through the vent while folding and rolling tank.

- (1) Remove dust cap (8 or 8.1) from water tank vent fitting (7) or vent pipe (7.1).
 - (2) Working from sides of water tank (13) (sides with longest length), tightly fold both sides in toward center of tank as shown. Brush off any stones, dirt, twigs or debris that stick to tank fabric.
 - (3) Roll tank toward vent fitting (7) or vent pipe (7.1). Install dust cap (8) and close locking arms or install threaded dust cap (8.1) and tighten fully.
 - (4) Tie tank bundle.
 - (5) Remove water tank (13) from ground cloth (14).
 - (6) Fold ground cloth (14) into bundle. Remove any stones, dirt, twigs or debris that stick to ground cloth.
 - (7) Tie ground cloth (14) bundle.
- c. Packing. If water tank is supplied as part of the 40K water distribution system, refer to TM 5-4610-234-13 for instructions on packing water tank in re-useable container.

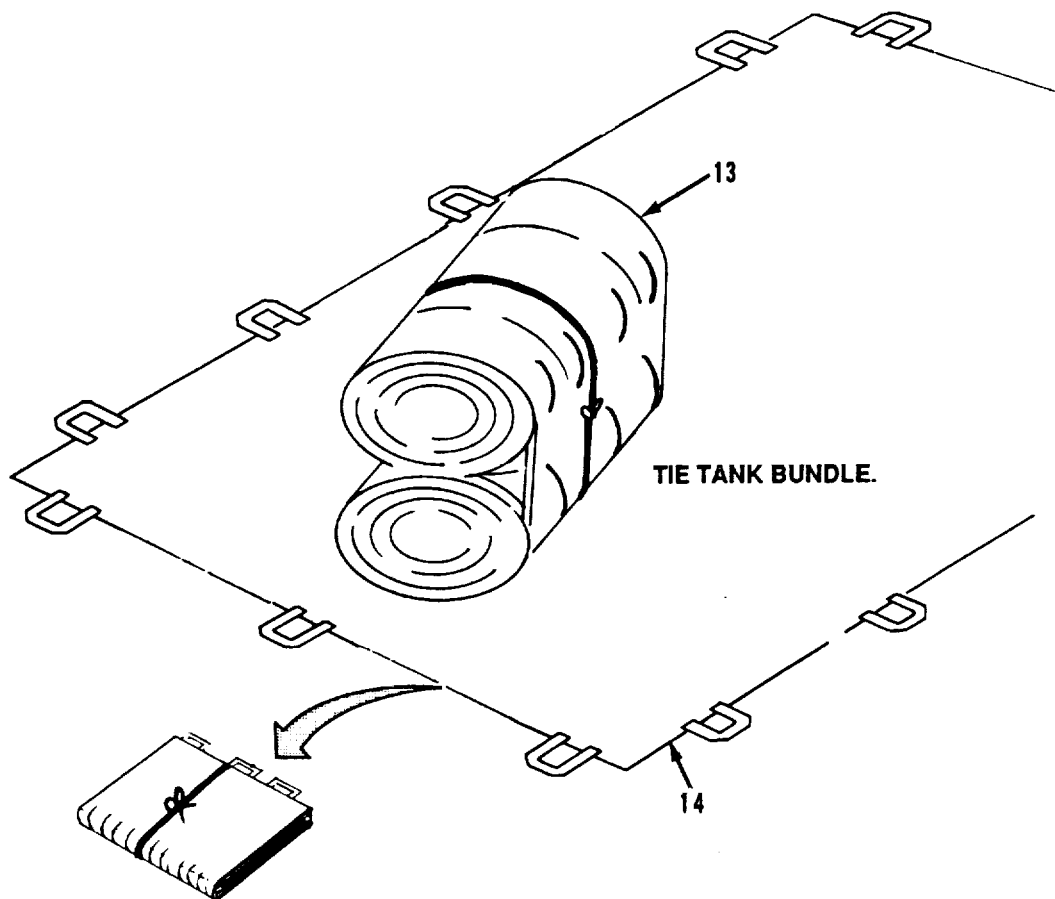

2-11. DECALS AND INSTRUCTION PLATES.

Instruction plates are used on the 20K and 50K water tanks to advise the operator of proper operating procedures. Stencils provide additional operating information and cautions to be observed during use of the equipment. The following illustration shows the instruction plates and stencils and identifies their location on the unit.

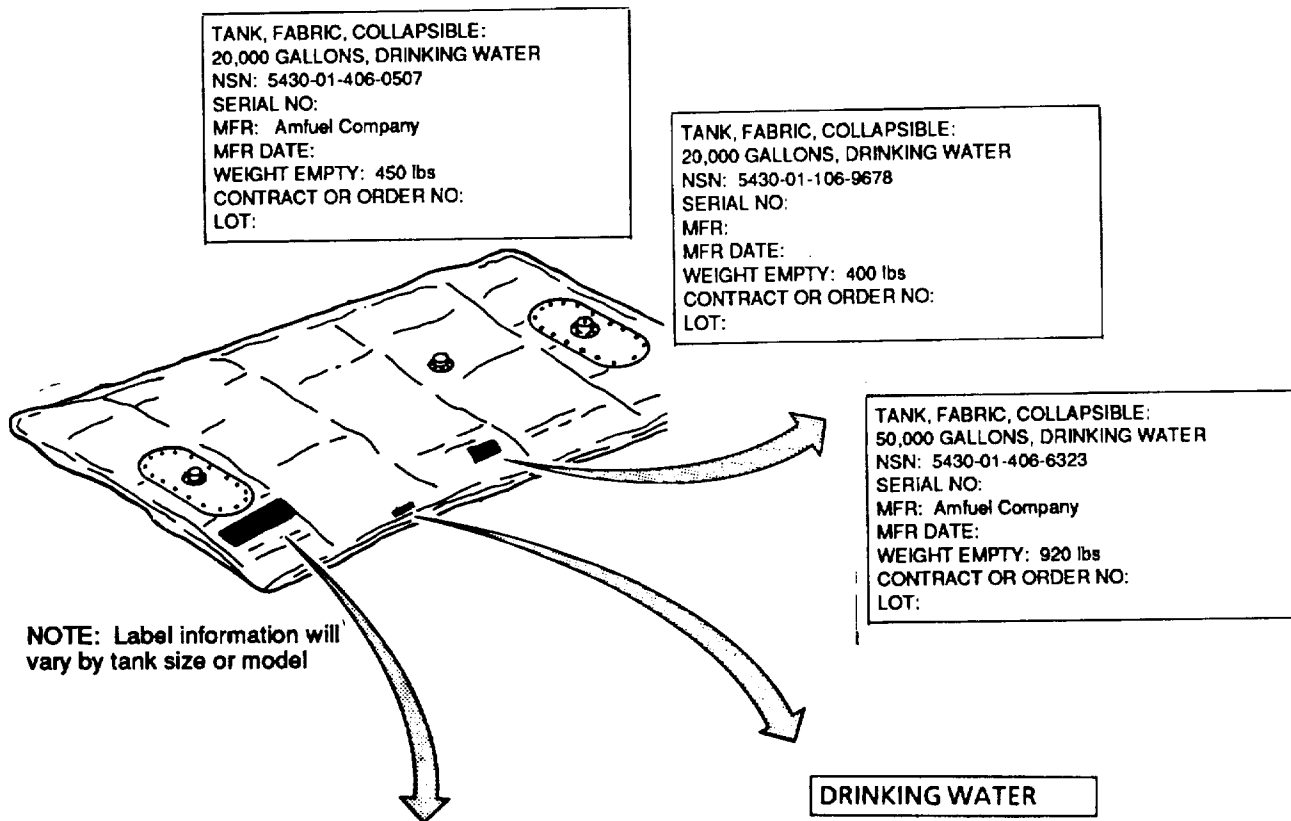

CAUTION
OVERFILLING WILL RESULT IN PERMANENT DAMAGE AND FAILURE OF TANK
DO NOT OVERFILL
MAXIMUM CAPACITY IS 20,000 GALLONS WHEN FULL
MAXIMUM TANK HEIGHT IS 5.7 FEET/1.74 METERS.

CAUTION
OVERFILLING WILL RESULT IN PERMANENT DAMAGE AND FAILURE OF TANK
DO NOT OVERFILL
MAXIMUM CAPACITY IS 50,000 GALLONS WHEN FULL
MAXIMUM TANK HEIGHT IS 5.7 FEET/1.74 METERS.

CAUTION
OVERFILLING WILL RESULT IN PERMANENT DAMAGE AND FAILURE OF TANK
DO NOT OVERFILL
MAXIMUM CAPACITY IS 20,000 GALLONS WHEN FULL
MAXIMUM TANK HEIGHT IS 5 FEET 6 INCHES/1.68 METERS.

Section IV. OPERATION UNDER UNUSUAL CONDITIONS

	Page
Operation in Extreme Cold	2-18
Operation in Extreme Heat	2-18
Operation in Dusty or Sandy Areas	2-18

2-12. OPERATION IN EXTREME COLD.

Observe the following precautions when operating the water tank in extreme cold:

- a. Keep snow and ice from collecting on top of tank.
- b. Keep snow and ice clear of vent assembly.
- c. Remove snow and ice from quick disconnect couplings before making connections.
- d. Avoid unnecessary folding, unfolding or rolling of tank in freezing temperatures. Cracks can develop in tank fabric.
- e. When possible, setup and operate water tank from heated shelter.
- f. Wear arctic mittens when handling water tank fittings. Change mittens if they get wet.

2-13. OPERATION IN EXTREME HEAT.

Observe the following precautions when operating the water tank in extreme heat:

- a. Protect water tank from extreme heat by covering with tarp, setting up tank in shaded area, or constructing a sun block.
- b. Ventilate area around water tank. Make sure air flow can circulates freely around tank.
- c. Avoid unnecessary folding, unfolding or rolling of empty water tank. Do not store unused tank in direct sunlight.

2-14. OPERATION IN DUSTY OR SANDY AREAS.

Observe the following precautions when operating the water tank in dusty or sandy areas:

- a. Keep dust caps in place on fittings and couplings until ready for use.
- b. Carefully inspect coupling gaskets. Dust or dirt on gaskets will cause leaks. Remove dust and dirt from gaskets before connecting couplings.

**CHAPTER 3
OPERATOR MAINTENANCE**

- Section I. Lubrication Instructions**
- Section II. Operator Troubleshooting Procedures**
- Section III. Operator Maintenance Procedures**

Section I. LUBRICATION INSTRUCTIONS

No lubrication of the 20K or 50K Gallon Collapsible Fabric Water Tank is required.

Section II. OPERATOR TROUBLESHOOTING PROCEDURES

	Page
Introduction	3-1
Troubleshooting	3-1

3-1. INTRODUCTION.

- a. Table 3-1 lists the common malfunctions which you may find during operation or maintenance of the 20K and 50K Gallon Collapsible Fabric Tanks or its components. You should perform the tests/inspection and corrective actions in the order listed.
- b. This manual cannot list all malfunctions that may occur, nor all tests or inspections and corrective actions. If a malfunction is not listed or is not corrected by listed corrective actions, notify your supervisor.

3-2. TROUBLESHOOTING.

Refer to Table 3-1.

Table 3-1. Operator Troubleshooting

WARNING

Be sure to read ALL Warnings in front of manual before troubleshooting.

MALFUNCTION	TEST OR INSPECTION	CORRECTIVE ACTION
--------------------	---------------------------	--------------------------

1. WATER TANK FABRIC LEAKS.

- Inspect water tank fabric for punctures, tears, and damaged seams.
- Install clamp patch or plug in tank fabric (para. 3-4).
- If leak cannot be repaired, notify unit maintenance.

3-2. TROUBLESHOOTING-cont.

Table 3-1. Operator Troubleshooting - cont.

MALFUNCTION	TEST OR INSPECTION	CORRECTIVE ACTION
-------------	--------------------	-------------------

2. DRAIN HOSE ASSEMBLY LEAKS.

- Step 1. Verify that drain hose control valve is closed.
Close control valve.
- Step 2. Inspect for water leakage at control valve stem.
Notify unit maintenance.
- Step 3. On tanks manufactured by Amfuel Company, inspect for water leakage at cam-lock couplings.
Verify that cam-lock levers are securely closed.
Notify unit maintenance.

WARNING

To prevent injury to personnel and damage to the equipment, do not open coupling lock arms when water is stored in tank.

NOTE

Some tanks have vent fitting assembly with a coupling connection near the base and some tanks have a single piece flanged pipe.

3. VENT FITTING ASSEMBLY LEAKS.

- Step 1. Determine whether this model has a vent pipe with a coupling connection. If so, check for loose vent pipe coupling connection.
Close coupling lock arms.
- Step 2. Check for loose or missing bolts on water tank coupling half.
If bolts are loose or missing, notify unit maintenance.

CAUTION

To prevent damage to water tank, the following steps should only be performed when tank is empty.

- Step 3. Check for dirt, bits of gravel, and debris on relief cap seal.
Lift relief cap and clean mating surfaces of relief cap and seal.
- Step 4. Check for bent or broken vent cap pivot pin.

**MALFUNCTION
TEST OR INSPECTION
CORRECTIVE ACTION**

If pin is damaged, notify unit maintenance.

4. FILLER/DISCHARGE ASSEMBLY LEAKS.

Step 1. Check for loose filler/discharge coupling connections.

Close coupling lock arms.

Step 2. Check for loose or missing bolts on water tank coupling half.

If bolts are loose or missing, notify unit maintenance.

Section III. OPERATOR MAINTENANCE PROCEDURES

	Page
General.....	3-3
Water Tank Repair.....	3-3

3-3. GENERAL.

This section contains procedures for performing operator maintenance on the 20K and 50K Gallon Collapsible Water Tanks. Operator maintenance is limited to installation of temporary clamp patches and plugs supplied in the tank repair kit.

3-4. WATER TANK REPAIR.

- a. General. Slits, tears or cuts in the water tank smaller than 6 1/2 inches are repaired with sealing clamps. Small punctures are repaired using the wooden plugs. Damage larger than 6 1/2 inches requires replacement of the water tank.
- b. Emergency Repairs. In emergencies, the wooden plugs supplied in the repair kit may be used to temporarily seal small holes or punctures to allow continued operation. To install the plugs, proceed as follows:

Repairs with plugs

- (1) Select size of plug required.

Hole Size		Plug Size
Up to 1/2-inch	use→	3-inch long plug
Up to 1 1/2 inches	use→	5-inch long plug

3-4. WATER TANK REPAIR -cont.

- (2) Push small end of plug in hole. Turn plug clockwise until tight. Tank leak should slow down, then stop as plug is tightened.
- (3) Continue your mission. Check plug during operation. If repair begins to leak, tighten plug again.
- (4) When mission is complete, replace plug with sealing clamp.

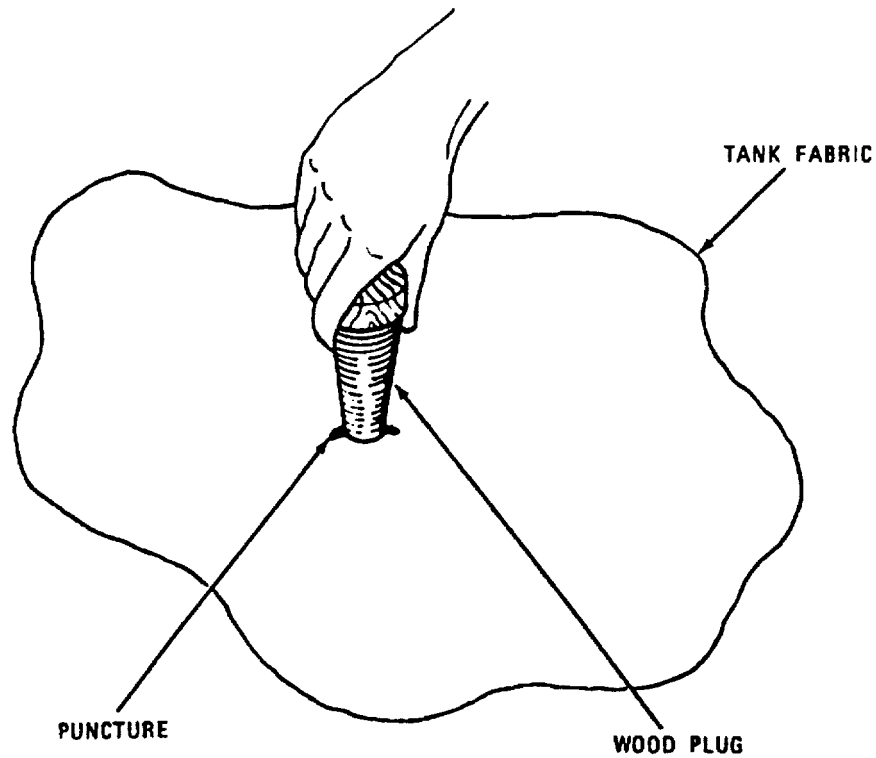

Repairs with Sealing Clamps.

- (1) Select size of sealing clamp required.

Hole Size		Clamp Size
Up to 2-inches	use→	3-inch clamp
2 to 4-inches	use→	5-inch clamp
4 to 6-inches	use→	7 1/2-inch clamp

- (2) Insert bottom plate through tear. Use a knife (Appendix C, Sec. III, item 2) to enlarge hole if clamp bottom plate will not fit through tear. Enlarge hole equally on both sides of tear.
- (3) Rotate bottom plate clamp bolt 1/4 turn or as required to center bottom plate under tear. Pull and hold lanyard to keep plate centered.
- (4) Slide top plate and wing nut down onto threaded portion of clamp bolt. Position top plate directly over bottom plate. Tighten wing nut until tank fabric is securely clamped and leak has stopped.
- (5) If tear is too large to be repaired by sealing clamp, notify unit maintenance.

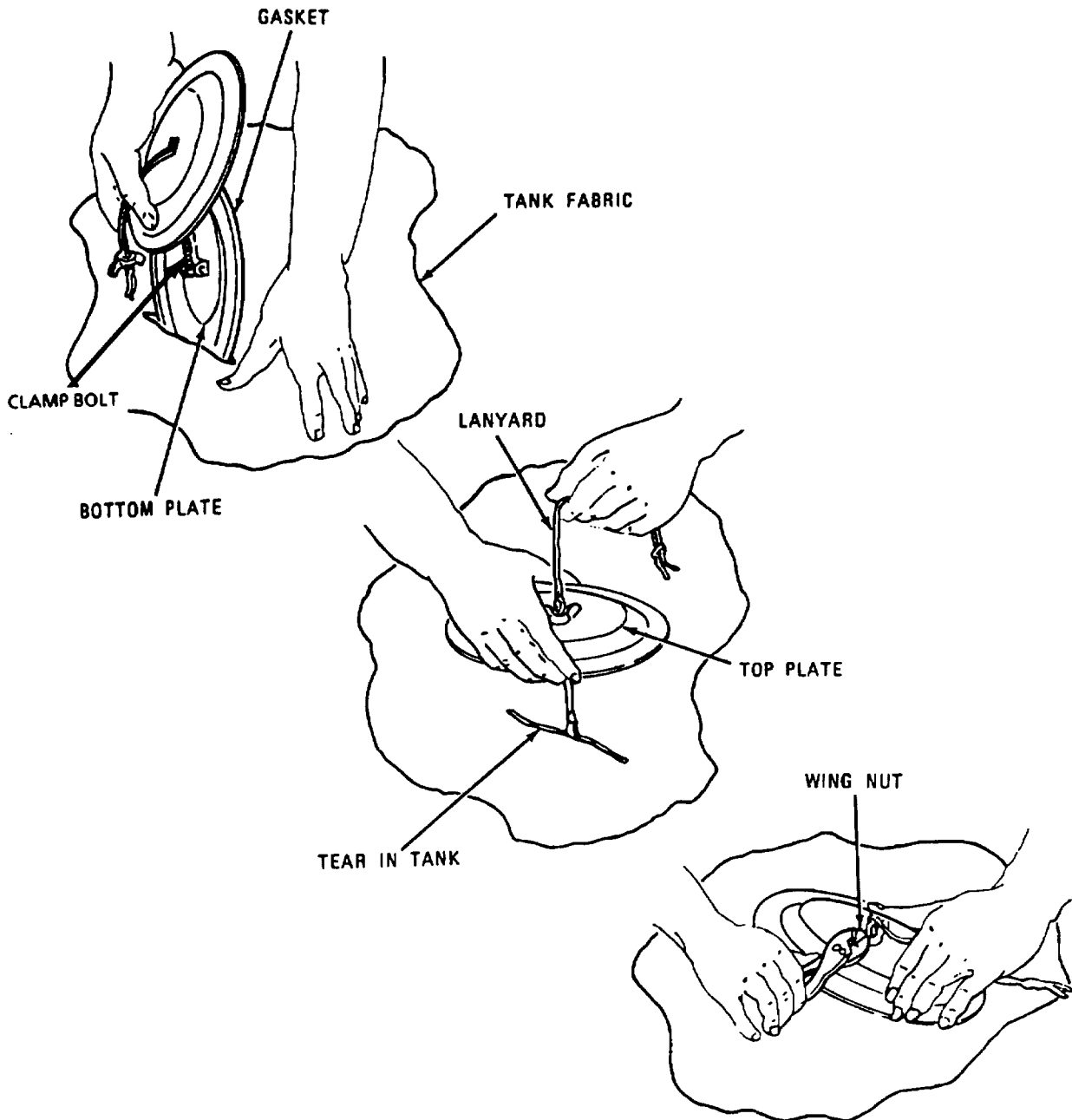

**CHAPTER 4
UNIT MAINTENANCE**

- Section I. Repair Parts, Special Tools; Test, Measurement and Diagnostic Equipment (TMDE); and Support Equipment
- Section II. Service Upon Receipt
- Section III. Unit Preventive Maintenance, Checks and Services (PMCS)
- Section IV. Unit Troubleshooting Procedures
- Section V. Unit Maintenance Procedures
- Section VI. Preparation for Storage or Shipment

Section I. REPAIR PARTS, SPECIAL TOOLS; TEST, MEASUREMENT AND DIAGNOSTIC EQUIPMENT (TMDE); AND SUPPORT EQUIPMENT

	Page
Common Tools and Equipment	4-1
Repair Parts	4-1
Special Tools, TMDE and Support Equipment Repair Parts	4-1

4-1. COMMON TOOLS AND EQUIPMENT.

For authorized common tools and equipment refer to the Modified Table of Organizational and Equipment (MTOE) applicable to your unit..

4-2. SPECIAL TOOLS, TMDE, AND SUPPORT EQUIPMENT.

No special tools or equipment are required to maintain the 20K or 50K Gallon Collapsible Fabric Tank systems.

4-3. REPAIR PARTS.

Repair parts are listed and illustrated in the repair parts and special tools list (TM 10-5430-226-20P) covering unit maintenance for this equipment.

Section II. SERVICE UPON RECEIPT

	Page
Introduction	4-1
Site Selection	4-2
Checking Unpacked Equipment	4-2
Unpacking.....	4-2

4-4. INTRODUCTION.

If the 20K Gallon Collapsible Fabric Tank is supplied as part of the 40K Water Distribution System, the water tank may be packaged in a reusable container.

4-5. SITE SELECTION.

a. Site selection must consider where and in what configuration the water tank will be used within the water distribution system. Siting and installation of the water distribution system will limit where the water tank can be setup. Refer to applicable system manual for specific water tank siting requirements.

b. Site selected must be level and free of rocks, sticks, gravel, and debris.

4-6. UNPACKING.

NOTE

The water tank may be packed in a reusable container, wooden crate or cardboard box when received.

a. If the 20K Gallon Collapsible Fabric Tank is received as part of the 40K Water Distribution System, tank will be packed in a reusable container. Refer to TM 10-4610-234-13 for specific unpacking instructions.

b. If the water tank is received in a wooden shipping crate, proceed as follows:

- (1) Cut banding straps from crate.
- (2) Remove top from crate.
- (3) Position crate on its side and roll tank from crate. Use care to avoid damaging tank.
- (4) Remove tank components from crate.

4-7. CHECKING UNPACKED EQUIPMENT.

a. Inspect the equipment for damage incurred during shipment. If the equipment has been damaged, report the damage on DD Form 6, Packaging Improvement Report.

b. Unwrap and examine components to ensure they are in serviceable condition.

c. Check the equipment against the packing slip to see if the shipment is complete. Report all discrepancies in accordance with instructions of DA PAM 738-750.

d. Check to see if equipment has been modified.

e. Remove all protective compounds and covering such as wax paper, waterproof tape, and barrier material. Remove preservatives and greases from unpainted, threaded, or exposed surfaces.

Section III. UNIT PREVENTIVE MAINTENANCE CHECKS AND SERVICES

	Page
Preventive Maintenance Checks and Services.....	4-3

4-8. PREVENTIVE MAINTENANCE CHECKS AND SERVICES (PMCS)

a. **General.** This section contains the procedures and instructions necessary to perform unit PMCS. These services are to be performed by unit maintenance personnel with the assistance, where applicable, of the operator/crew. Your PMCS is performed to find and fix problems before they cause major damage to the equipment. Perform the PMCS in the order listed.

b. PMCS Procedures. Refer to Table 4-1.

(1) **Item Number Column.** Checks and services are numbered in chronological order regardless of interval. This column is used as a source of item number for the "TM Number" column on DA Form 2404, Equipment Inspection and Maintenance Worksheet, in recording results of PMCS.

(2) **Interval Column.** The interval column tells you when to do a certain check or service. Unit PMCS on the water tank is performed quarterly.

- | | |
|-----------------|-----------------------------|
| Q = Quarterly | -every 90 days (3 months) |
| S = Semi-annual | -every 180 days (6 months) |
| A = Annual | -every 365 days (12 months) |

(3) **Item To Be Inspected Column.** The column lists the common name of the item to be inspected, such as "Gate Valve"

(4) **Procedures Column.** This column tells you how to do the required checks or services. Carefully follow these instructions. If you do not have the tools or if the procedures tell you to, have direct support maintenance do the work.

c. Prior to Storage or Shipment. A complete PMCS must be performed prior to storage or shipment of the water tank.

Table 4-1. Unit Preventive Maintenance Checks and Services

Item No.	Interval			Item to be Inspected	Procedures
	Q	S	A		
1				Tank, Fabric Collapsible, 20,000 Gallon or 50,000 Gallon (End item)	Inspect for missing components.
2				Water Tank	<ul style="list-style-type: none"> a. Inspect for tears, punctures, and loose seams. b. Inspect for loose or missing bolts on filler/discharge closure plates. c. Check for missing dust covers.
3				Vent Fitting Assembly	<ul style="list-style-type: none"> a. Inspect vent cap for cracks and bent pivot pin. b. Check vent cap movement. Cap should move freely without sticking or binding.
4				Fill/Discharge Assemblies	<ul style="list-style-type: none"> a. Inspect elbows for cracks. b. Inspect for missing coupling gaskets. c. Inspect for broken coupling lock arms. d. Inspect for missing dust cap and plug.
5				Drain Assembly	<ul style="list-style-type: none"> a. Inspect for cracks. b. Inspect for missing drain plug.
6				Hose Assembly (Drain)	<ul style="list-style-type: none"> a. Inspect for cuts, punctures and missing band clamps. b. Inspect for damaged threads on pipe nipples.
7				Drain Valve	<ul style="list-style-type: none"> a. Inspect for loose or missing valve handle. b. Check for bent valve stem. c. On tanks manufactured by Amfuel Company, inspect couplings for cracks. d. On tanks manufactured by Amfuel Company, inspect for missing coupling gaskets. e. On tanks manufactured by Amfuel Company, inspect for damaged coupling arms. f. On tanks manufactured by Amfuel Company, inspect for missing dust cap and plug.
8				4-inch Gate Valve	<ul style="list-style-type: none"> a. Inspect for loose, damaged or missing valve handle. b. Check for bent valve stem. c. Inspect for missing coupling gaskets. d. Inspect for broken coupling lock arms. e. Inspect for missing dust cap and plug. f. Inspect for loose or missing bolts and nuts.
9				Ground Cloth	Inspect for large tears.
10				Repair Kit	Inspect for missing components.

Section IV. UNIT TROUBLESHOOTING PROCEDURES

Introduction	Page 4-5
Troubleshooting	4-5

4-9. INTRODUCTION.

- a. Table 3-1 lists the common malfunctions which you may find during operation or maintenance of the 20K or 50K Gallon Collapsible Fabric Tanks or its components. You should perform the tests/inspection and corrective actions in the order listed.
- b. This manual cannot list all malfunctions that may occur, nor all tests or inspections and corrective actions. If a malfunction is not listed or is not corrected by listed corrective actions, notify your supervisor.

4-10. TROUBLESHOOTING.

Refer to Table 4-1.

Table 4-1. Unit Troubleshooting

WARNING

Be sure to read ALL Warnings in front of manual before troubleshooting.

MALFUNCTION

TEST OR INSPECTION

CORRECTIVE ACTION

1. DRAIN HOSE ASSEMBLY LEAKS.

- Step 1. Inspect drain control valve stem packing for leakage.
Replace drain control valve (para. 4-17).
- Step 2. Shut off drain control valve. Water should not leak through valve.
Replace drain control valve (para. 4-17).
- Step 3. Inspect drain hose assembly for cuts, tears, and punctures.
If drain hose is damaged, replace hose assembly (para. 4-17).
- Step 4. On tanks manufactured by Amfuel Company, inspect cam-lock couplings for cracks, broken locking arms, and damaged or missing coupling gaskets. Replace coupling or coupling gaskets if needed (para. 4-17).
- Step 5. On tanks manufactured by Amfuel Company, check for missing dust cap or dust plug.
Replace if needed (para. 4-17).

Table 4-1. Unit Troubleshooting - cont.

MALFUNCTION	TEST OR INSPECTION	CORRECTIVE ACTION
-------------	--------------------	-------------------

2. VENT FITTING ASSEMBLY LEAKS.

WARNING

To prevent injury to personnel and damage to the equipment, do not open coupling lock arms when water is stored in tank.

NOTE

Some tanks have a vent pipe with a cam-lock coupling at the base and some have a vent pipe welded to the base. Maintenance instructions for vents with cam-lock couplings are given in para. 4-14. Maintenance instructions for vents with welded bases are given in para. 4-19.

- Step 1. Inspect for distorted, cracked, cut or missing vent cap gasket.
Replace vent cap (para. 4-14 or para. 4-19). See NOTE above.
- Step 2. Inspect for bent or broken vent cap hinge pin.
Replace vent cap (para. 4-14 or para. 4-19). See NOTE above.
- Step 3. Inspect vent pipe for cracks. If present, inspect coupling for cracks, broken locking arms, and damaged or missing coupling gasket.
Replace vent pipe or coupling (para. 4-14 or para. 4-19). See NOTE above.
- Step 4. Check for loose or missing bolts on water tank coupling half.
Replace missing bolts and washers.
Torque loose bolts to 30 inch-pounds. On tanks manufactured by Amfuel Company, torque loose bolts to 40-60 inch-pounds.
- Step 5. Remove flange from water tank (para. 4-14 or para. 4-19). See NOTE above. Inspect flanged piece for cracks or scratched sealing surface. Inspect o-ring for cuts, tears, and distortion.
Replace coupling half, if damaged.
Replace o-ring, if damaged.
- Step 6. Inspect water tank compression fitting for cuts, punctures, elongated holes and tears.
If compression fitting or tank fabric is damaged, replace water tank.

3. FILLER/DISCHARGE ASSEMBLY LEAKS.

- Step 1. Inspect filler/discharge elbows for cracked, torn, distorted or missing coupling gaskets.
Replace elbows or coupling gaskets if damaged (para. 4-15).

Table 4-1. Unit Troubleshooting - cont.

MALFUNCTION**TEST OR INSPECTION****CORRECTIVE ACTION**

Step 2. Check for loose or missing bolts on water tank flanged male coupling half.

Replace missing bolts and washers.

Torque loose bolts to value specified on water tank.

Step 3. Check for loose or missing bolts on closure plate compression fitting.

Replace missing bolts and washers.

Torque loose bolts to 30 inch-pounds. On tanks manufactured by Amfuel Company, torque bolts to 40-60 inch-pounds.

Step 4. Remove water tank flanged male coupling half from closure plate (para. 4-15). Inspect flange gasket for cuts, tears and distortion.

Replace gasket.

Step 5. Remove closure plate from water tank (para. 4-15). Inspect plate for cracks. Inspect o-ring for cuts, tears and distortion.

Replace closure plate and o-ring (para. 4-15), if damaged.

Step 6. Inspect water tank compression fitting for cuts, punctures, elongated holes and tears.

If compression fitting or tank fabric is damaged, replace water tank.

4. DRAIN FITTING ASSEMBLY LEAKS.

Step 1. Check for loose or missing bolts on drain fitting assembly.

Replace missing bolts and washers.

Torque loose bolts to 30 inch-pounds.

Step 2. Remove drain fitting from water tank (para. 4-16) and inspect for cracks. Inspect o-ring for cuts, tears, and distortion.

Replace drain fitting, if damaged.

Replace o-ring, if damaged.

Step 3. Inspect water tank compression fitting for cuts, punctures, elongated holes and tears.

If compression fitting or tank fabric is damaged, replace water tank.

Section V. UNIT MAINTENANCE PROCEDURES

	Page
Collapsible Fabric Tank Maintenance	4-8
Drain Fitting Assembly Maintenance	4-18
Drain Hose Assembly Maintenance	4-20
Filler/Discharge Assembly Maintenance	4-14
General	4-8
Ground Cloth Maintenance	4-26
Removing Equipment From Storage	4-26
Repair Kit Maintenance	4-26
Storage	4-26
Vent Fitting Assembly Maintenance, Cam-lock Style	4-9
Vent Fitting Assembly Maintenance, Welded Base Style	4-12
Water Tank Maintenance	4-8
4-Inch Gate Valve Assembly Maintenance	4-22

4-11. GENERAL.

This section contains procedures for performing unit level maintenance on the 20K and 50K Gallon Collapsible Fabric Water Tanks.

CAUTION

Fabric tank must be empty before performing unit maintenance. Be careful when walking on tank fabric. Gravel and sand stuck on the bottom of your boots will damage tank fabric.

4-12. COLLAPSIBLE FABRIC TANK MAINTENANCE.

Maintenance of the 20K or 50K Gallon Collapsible Fabric Tank (system) is limited to replacement and repair. Replacement consists of turning the equipment in at the proper supply point and then requisitioning a replacement unit. Repair is accomplished by replacing or repairing components that make up the system.

4-13. WATER TANK MAINTENANCE.

- a. General. Water tank replacement is required when rips, tears, or punctures are too large or too numerous to be corrected using the repair kit.
- b. Replace. Replacement of the water tank consists of requisitioning a replacement item.

4-14. VENT FITTING ASSEMBLY MAINTENANCE (BELL-AVON MODEL ETQ).**NOTE**

These instructions apply only to vent fitting assemblies with a cam-lock coupling near the base. For vent fittings with the vent pipe welded to the base, refer to paragraph 4-14.1 for maintenance instructions.

This task covers:

- | | | |
|-----------------------|----------------------|------------------------|
| a. Removal | d. Inspection | g. Installation |
| b. Disassembly | e. Repair | |
| c. Cleaning | f. Assembly | |

INITIAL SET-UP:

Tools required:

- Tool Kit, General Mechanics, Automotive (Appendix B, Sec. In, item 1)
- Torque Wrench (0-50 Inch-Pounds) (Appendix B, Sec. III, item 2)
- Pipe Wrench, 12 inch (Appendix B, Sec. III, item 2)

Materials/Parts required:

- Detergent, General Purpose (Item 1, Appendix D)
- Rag, Wiping (Item 2, Appendix D)
- Tape, Anti-seize (Item 3, Appendix D)
- Coupling Gasket (2) - MS27030-6
- Gasket - EX1333B-2
- O-ring - MS29513-250

Equipment Condition:

- Water tank empty.

a. Removal.

- (1) Open lock arms (3) on coupling (2).
- (2) Disconnect vent assembly (1) from flanged coupling (4).

b. Disassembly.

- (1) Remove coupling gasket (15) from coupling (2).
- (2) Unscrew coupling (2) from vent pipe (8) using pipe wrench.
- (3) Unscrew vent cap (6) and remove gasket (7).
- (4) Remove eight bolts (14), eight washers (13), and dust cap (10) from flanged coupling (4).
- (5) Separate flanged coupling (4) and o-ring (12) from water tank (5).
- (6) Remove gasket (11) from dust cap (10).

4-14. VENT FITTING ASSEMBLY MAINTENANCE - cont.

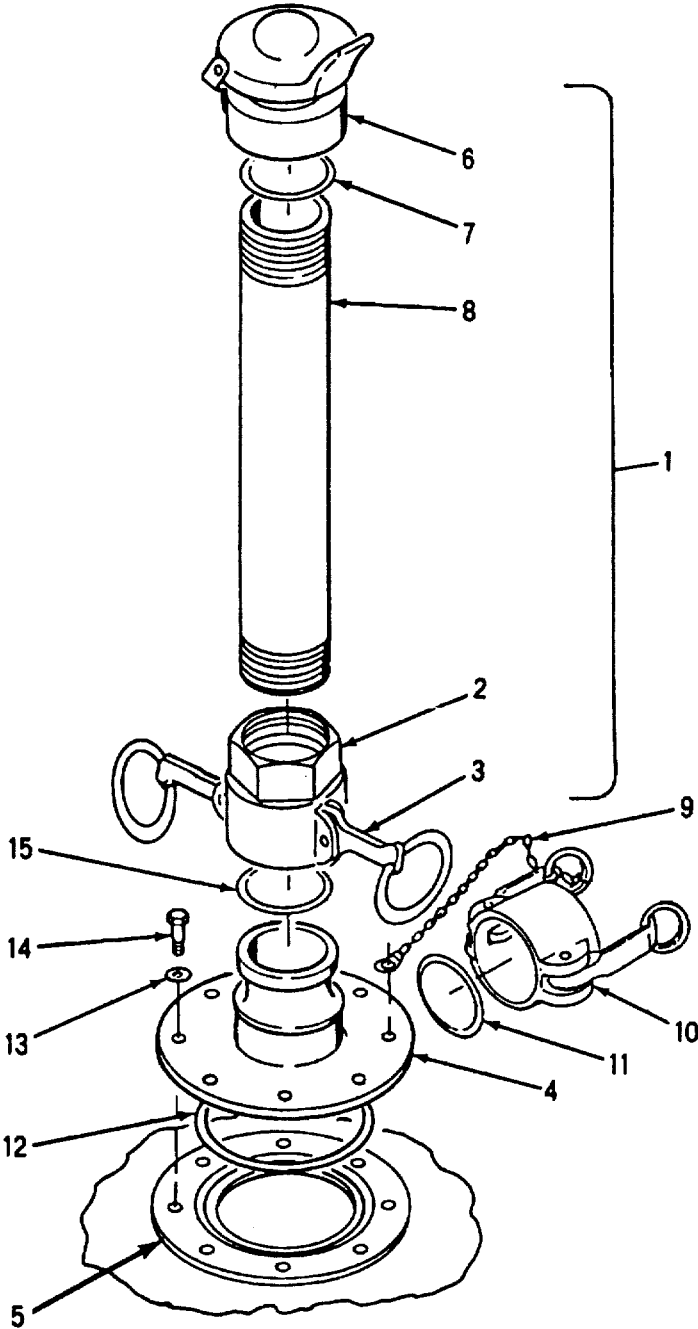

c. Cleaning.

- (1) Clean all components with clean water and detergent.
- (2) Rinse components in clean water and dry with wiping rag.

d. Inspection.

- (1) Inspect coupling (2) for cracks, corrosion, and stripped threads.
- (2) Inspect pipe (8) for cracks, stripped threads, and corrosion.
- (3) Inspect vent cap (6) for bent or damaged pivot pin. Check for freedom of movement. Inspect for cracked, cut or dirty sealing gasket.
- (4) Inspect water tank compression fitting (5) for stripped threads.

e. Repair. Replace damaged components. Do not reuse sealing components. Replace all gaskets and o-rings.

f. Assembly.

- (1) Install new gasket (11) in dust cap (10).
- (2) Position o-ring (12) and flanged coupling (4) on water tank compression fitting (5).
- (3) Install chain (9), dust cap (10), eight washers (13) and eight bolts (14). Torque bolts to 30 inch-pounds.
- (4) Apply anti-seize tape to threaded ends of pipe (8). Wrap tape in a clockwise direction.
- (5) Position gasket (7) in vent cap (6). Screw vent cap onto pipe (8) until hand tight.
- (6) Screw coupling (2) onto pipe (8).
- (7) Install new gasket (15) in coupling (2).

g. Installation.

- (1) Position vent assembly (1) on flanged coupling (4).
- (2) While pushing vent assembly (1) onto flanged coupling (4), close locking arms (3). Make sure coupling is securely locked.

4-15. VFNT FITTING ASSEMBLY MAINTENANCE (AMFUEL MODELS FLP, FLO).**NOTE**

These instructions apply only to vent fitting assemblies with the vent pipe welded to the base. For vent fittings with a cam-lock coupling near the base, refer to paragraph 4-14 for maintenance instructions.

This task covers:

- | | | |
|-----------------------|----------------------|------------------------|
| a. Removal | d. Inspection | g. Installation |
| b. Disassembly | e. Repair | |
| c. Cleaning | f. Assembly | |

INITIAL SET-UP:

Tools required:

- Tool Kit, General Mechanics, Automotive (Appendix B, Sec. III, item 1)
- Torque Wrench (0-120 Inch-Pounds) (Appendix B, Sec. III, item 2)
- Pipe Wrench, 12 inch (Appendix B, Sec. III, item 2)

Materials/Parts required:

- Detergent, General Purpose (Item 1, Appendix D)
- Rag, Wiping (Item 2, Appendix D)
- Tape, Anti-seize (Item 3, Appendix D)
- Gasket - EX1333-18
- O-ring - MS29513-250

Equipment Condition:

- Water tank empty.

-
- a. Removal.
 - (1) Remove eight bolts (1), eight washers (2), and dust cap (3) from flange area of the vent fitting assembly (4).
 - (2) Lift vent fitting assembly (4) from water tank compression fitting (5).
 - (3) Remove o-ring (6).
 - b. Disassembly. Unscrew vent cap (7) and remove gasket (8).
 - c. Cleaning.
 - (1) Clean all components with clean water and detergent.
 - (2) Rinse components in clean water and dry with wiping rag.
 - d. Inspection.
 - (1) Inspect vent pipe (9) for cracks, corrosion, and stripped threads.
 - (2) Inspect vent cap (7) for bent or damaged pivot pin. Check for cracked, cut, or dirty gasket (8).
 - (3) Inspect water tank compression fitting (5) for stripped threads.

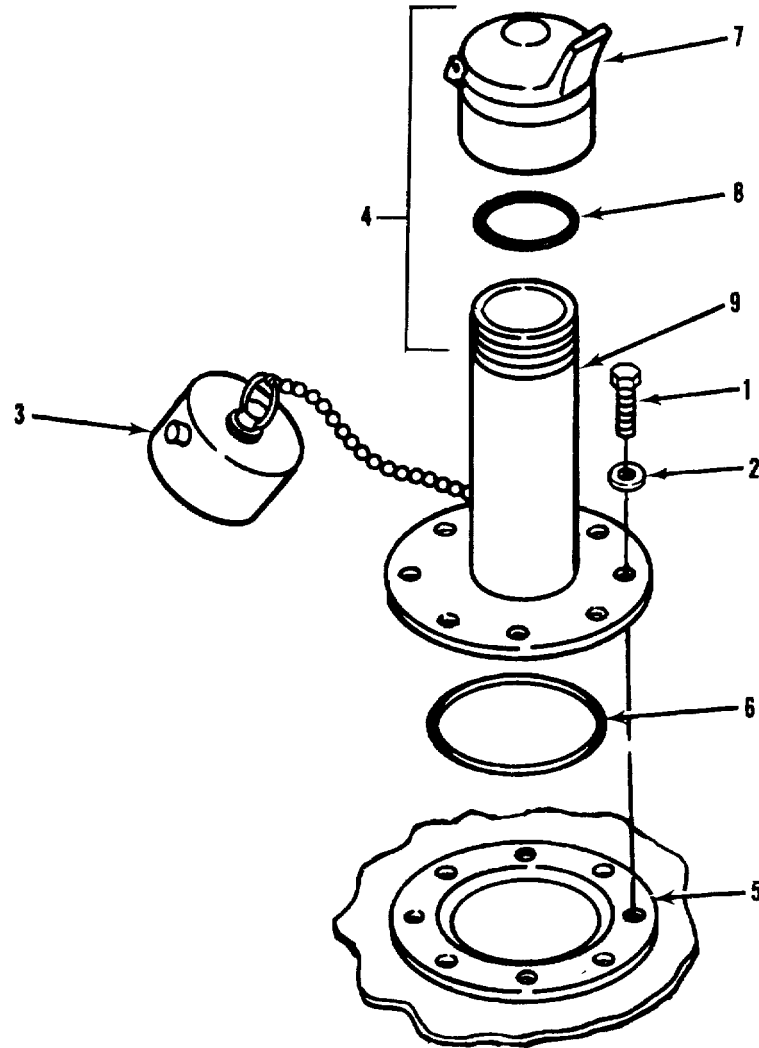

- e. Repair. Replace damaged components. Do not reuse sealing components. Replace all gaskets and o-rings.
- f. Assembly.
 - (1) Apply anti-seize tape to threaded end of pipe (9). Wrap tape in a clockwise direction.
 - (2) Position gasket (8) in vent cap (7). Screw vent cap onto pipe (9) until hand tight.
- g. Installation.
 - (1) Position o-ring (6) in compression fitting (5).
 - (2) Place vent fitting assembly (4) onto compression fitting (5).
 - (3) Install dust cap (3), eight washers (2), and eight bolts (1). Torque bolts to 40-60 inch-pounds.

4-16. FILLER/DISCHARGE ASSEMBLY MAINTENANCE.**This task covers:**

- | | | |
|-----------------------|----------------------|------------------------|
| a. Removal | d. Inspection | g. Installation |
| b. Disassembly | e. Repair | |
| c. Cleaning | f. Assembly | |

INITIAL SET-UP:

Tools required:

- Tool Kit, General Mechanics, Automotive (Appendix B, Sec. III, item 1)
- Torque Wrench (0-50 Inch-Pounds) (Appendix B, Sec. III, item 2)

Materials/Parts required:

- Detergent, General Purpose (Item 1, Appendix D)
- Rag, Wiping (Item 2, Appendix D)
- Tape, Anti-seize (Item 3, Appendix D)
- Coupling Gaskets (4) - MS27030-9
- Gasket - C2479M-4
- O-ring- MS9021-383

Equipment Condition:

- Water tank empty.

NOTE

The filler and discharge assemblies are similar. Only the 90° elbows are different. All procedures apply to both assemblies.

a. Removal.

- (1) Open locking arms on discharge elbow (1). Separate elbow from fanged coupling (14).
- (2) Open locking arms on filler elbow (17). Separate elbow from fanged coupling (14).

b. Disassembly.

- (1) Remove gaskets (16 and 18) from filler elbow (17).
- (2) Remove gasket (2) from discharge elbow (1).
- (3) Remove twenty bolts (12), washers (1) and dust cap (3) from closure plate (5).
- (4) Separate closure plate (5) and attached parts from compression fitting (20). Remove o-ring (7).

(5) Remove eight nuts (8), lockwashers (9) and suction stub (6). Remove eight sealing washers (10), bolts (15), flanged coupling (14) and gasket (13) from closure plate (5).

(6) Remove gasket (4) from dust cap (3).

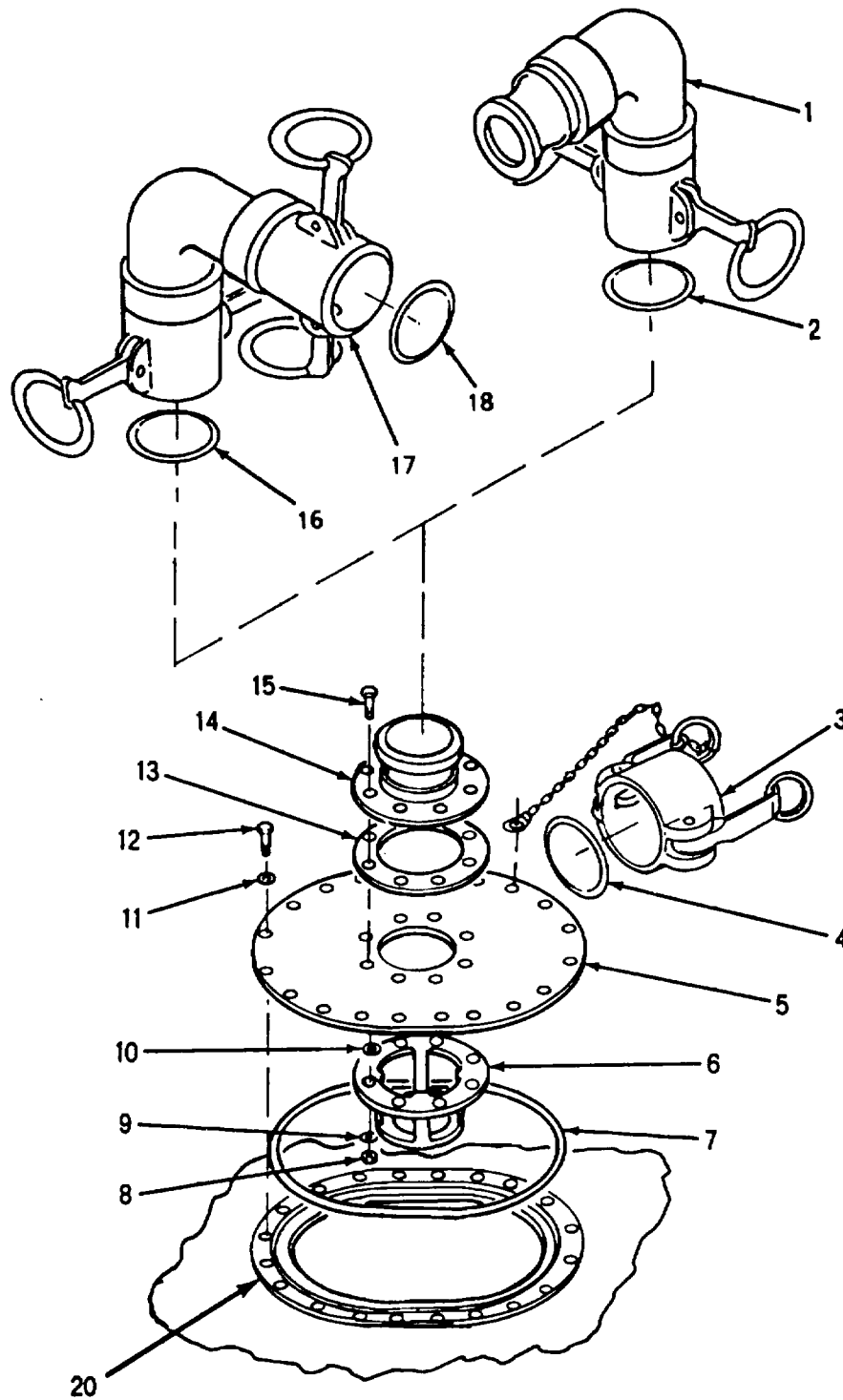

4-16. FILLER/DISCHARGE ASSEMBLY MAINTENANCE - cont.

c. Cleaning.

- (1) Clean all components with clean water and detergent.
- (2) Rinse components in clean water and dry with wiping rag.

d. Inspection.

- (1) Inspect filler and discharge elbows (17 and 1) for cracks, corrosion, scored mating surfaces and broken locking arms.
- (2) Inspect flanged coupling (14) for cracks, corrosion, and scored mating surface.
- (3) Inspect closure plate (5) for cracks, corrosion and elongated bolt holes.
- (4) Inspect suction stub (6) for cracks, corrosion and bent support arms.
- (5) Inspect dust cap (3) for cracks, broken locking arms, and missing or broken retaining chain.

e. Repair. Replace damaged components. Do not re-use sealing components. Replace all o-rings and gaskets.

f. Assembly.

- (1) Install new gasket (4) in dust cap (3).
- (2) Position gasket (13) and flanged coupling (14) on closure plate (5). Install eight bolts (15) and sealing washers (10). Position suction stub (6) on bolts (15). Install eight lockwashers (9) and nuts (8). Tighten nuts. On tanks manufactured by Amfuel Company, torque nuts to 120-125 inch-pounds.
- (3) Position new o-ring (7) and closure plate (5) on compression fitting (20). Align bolt holes and install twenty washers (11) and bolts (12). Torque bolts to 30 inch-pounds. On tanks manufactured by Amfuel, torque bolts to 40-60 inch-pounds.
- (4) Install new gasket (2) in discharge elbow (1).
- (5) Install new gaskets (16 and 18) in filler elbow (17).

g. Installation.

- (1) Open locking arms on filler elbow (17) coupling. Push elbow onto flanged coupling (14) and close locking arms.
- (2) Open locking arms on discharge elbow (1) coupling. Push elbow onto flanged coupling (14) and close locking arms.

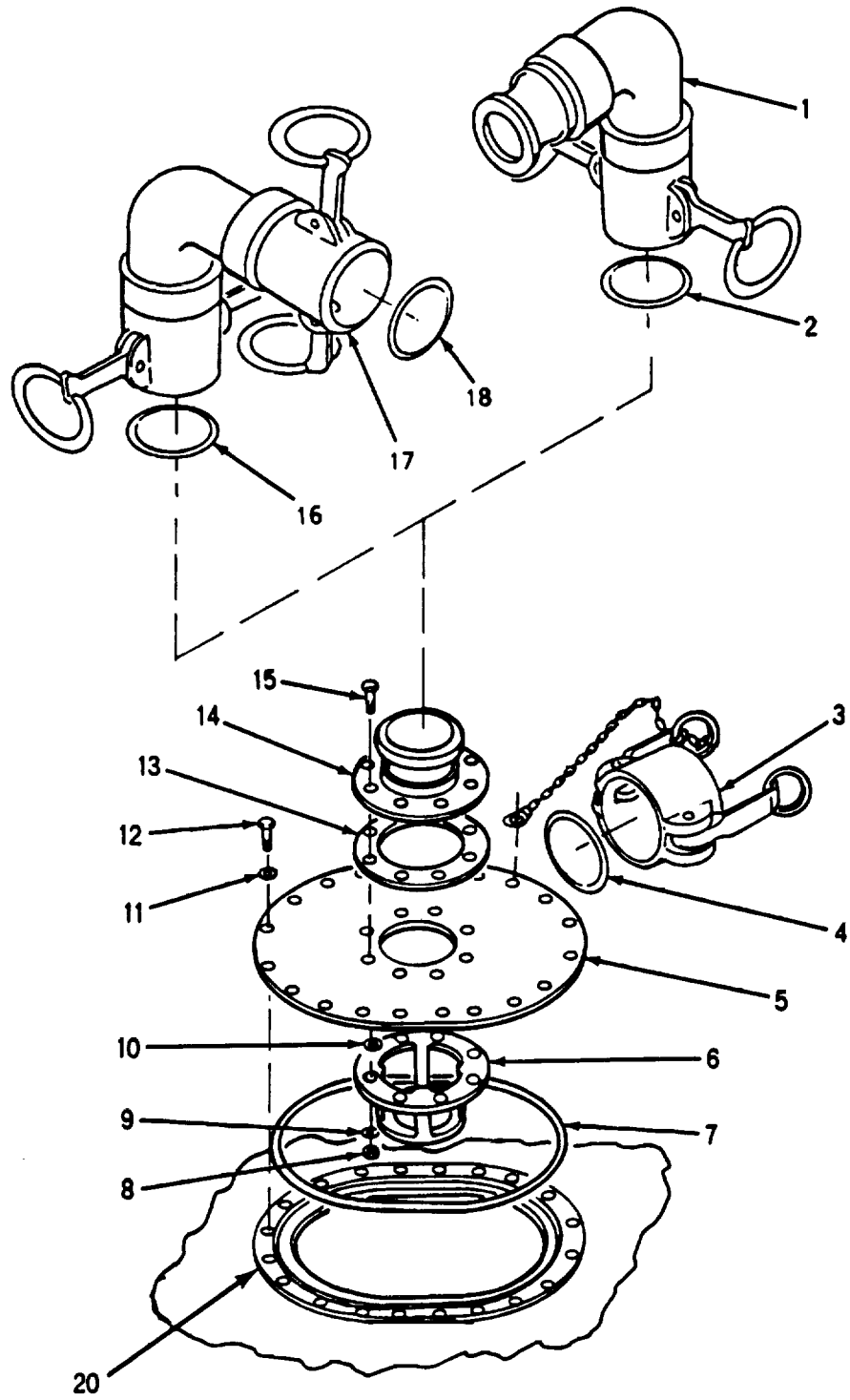

4-17. DRAIN FITTING ASSEMBLY MAINTENANCE.

This task covers:

- | | | |
|-----------------------|----------------------|------------------------|
| a. Removal | d. Inspection | g. Installation |
| b. Disassembly | e. Repair | |
| c. Cleaning | f. Assembly | |
-

INITIAL SET-UP:

Tools required:

- Tool Kit, General Mechanics, Automotive (Appendix B, Sec. III, item 1)
- Torque Wrench (0-50 Inch-Pounds) (Appendix B, Sec. III, item 2)

Materials/Parts required:

- Detergent, General Purpose (Item 1, Appendix D)
- Rag, Wiping (Item 2, Appendix D)
- Tape, Anti-seize (Item 3, Appendix D)
- O-ring- MS9513-250

Equipment Condition:

- Water tank empty.
-

a. Removal.

- (1) Remove eight bolts (4), washers (5) and chain (3) from drain fitting (6).
- (2) Remove drain fitting (6) and o-ring (7) from compression fitting (8).

b. Disassembly.

- (1) Remove screw (1) and chain (3) from drain plug (2).
- (2) Remove drain plug (2) from drain fitting (6)

c. Cleaning.

- (1) Wash all components with clean water and detergent.
- (2) Rinse components in clean water and dry with wiping rag.

d. Inspection.

- (1) Inspect drain fitting (6) and compression fitting (8) for cracks, corrosion, and stripped threads.
- (2) Inspect drain plug (2) for damaged threads.
- (3) Inspect chain (3) for broken links.

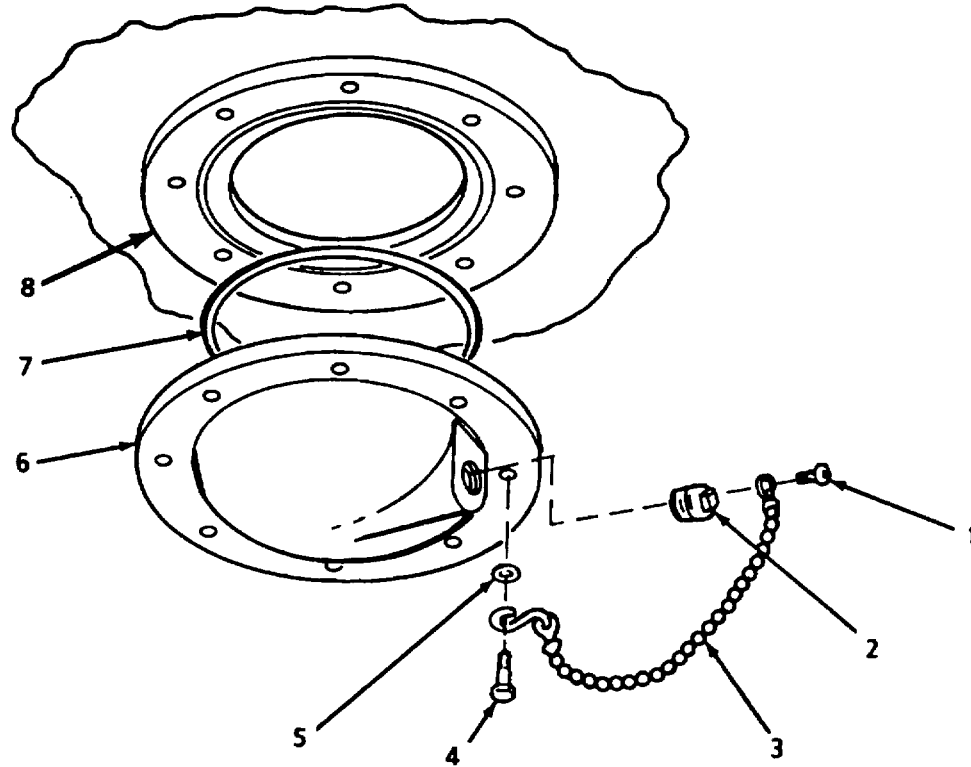

e. Repair. Replace damaged components. Do not re-use o-ring.

f. Reassembly.

(1) Connect chain (3) to plug (2) with screw (1).

(2) Apply anti-seize tape to drain plug (2) threads. Wind tape clockwise onto threads.

(3) Install plug (2) in drain fitting (6).

g. Installation.

(1) Position new o-ring (7) and drain fitting (6) on compression fitting (8).

NOTE

Ensure drain fitting plug points toward closest edge of water tank when installing drain fitting.

(2) Install eight washers (5), eight bolts (4) and connect chain (3) to drain fitting (6). Torque bolts to 30 inch-pounds. On tanks manufactured by Amfuel Company, torque bolts to 40-60 inch-pounds.

4-18. DRAIN HOSE ASSEMBLY MAINTENANCE.

This task consists of: **a. Removal** **b. Installation**

INITIAL SET-UP:

Tools required:

Tool Kit, General Mechanics, Automotive (Appendix B, Sec. III, item 1)

Materials/Parts required:

Tape, Anti-seize (Item 3, Appendix D)

Equipment Condition:

Water tank empty.

a. Removal.

- (1) Unscrew hose assembly (2) from drain fitting (1) using adjustable wrench.
- (2) Install plug (4) in drain fitting (1).
- (3) Unscrew drain valve (3) from hose assembly (2). See also step (4).
- (4) On tanks manufactured by Amfuel Company, open locking arms on quick-disconnect coupling (5) and separate ball valve (3.1) from hose assembly (2.1).

b. Installation.

- (1) Remove plug (4) from drain fitting (1).
- (2) Apply anti-seize tape to hose assembly (2) threaded fittings. Wind tape clockwise onto threads.
- (3) Screw hose assembly (2) into drain fitting (1).
- (4) Screw hose assembly (2) into drain valve (3). See also step (5)
- (5) On tanks manufactured by Amfuel Company, open locking arms on quick-disconnect coupling (5) and push onto coupling half attached to hose assembly (2.1). Close locking arms to complete connection.
- (6) Close drain valve (3 or 3.1).

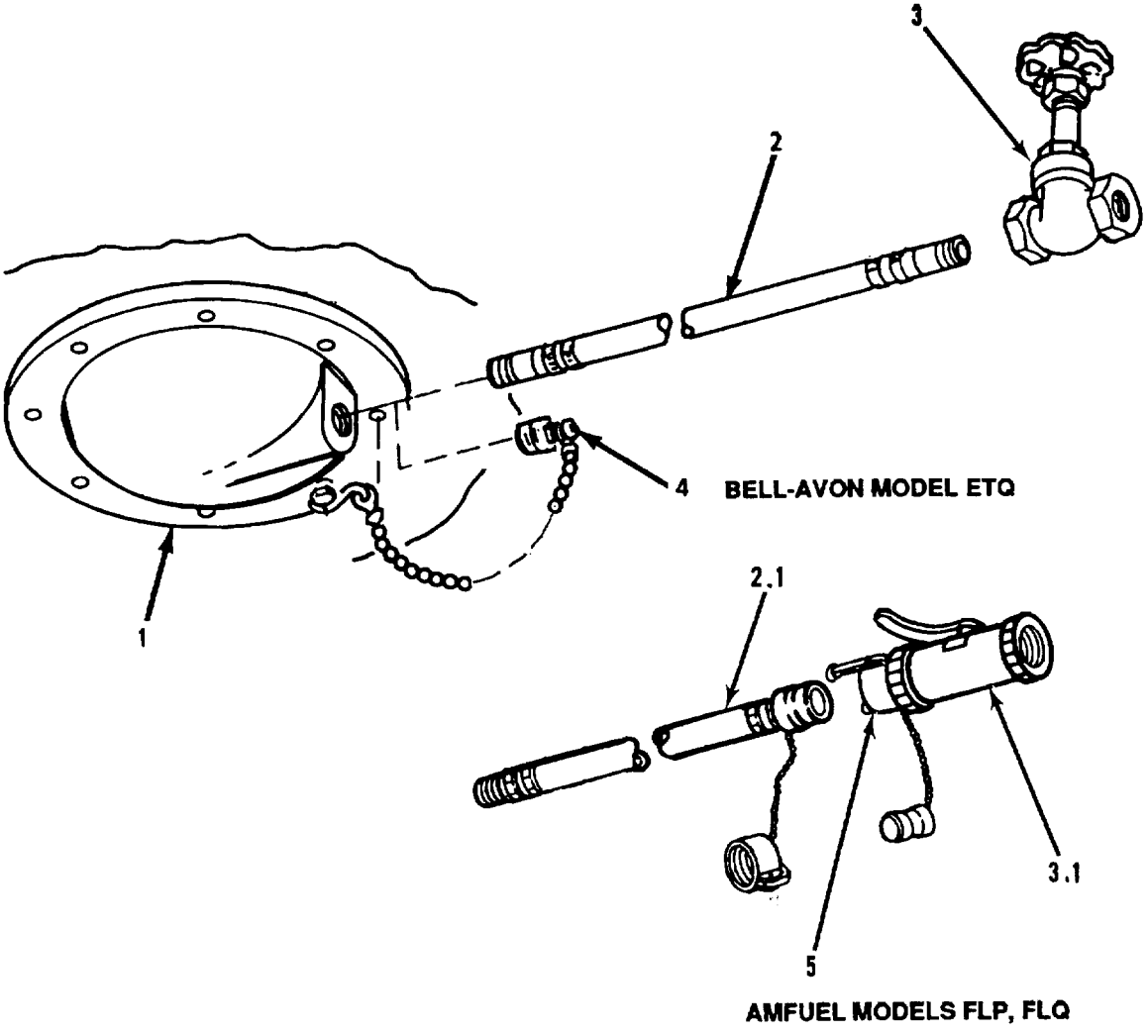

4-19. 4-INCH GATE VALVE MAINTENANCE - cont.**This task covers:**

- | | | |
|-----------------------|----------------------|------------------------|
| a. Removal | d. Inspection | g. Installation |
| b. Disassembly | e. Repair | |
| c. Cleaning | f. Assembly | |

INITIAL SET-UP:

Tools required:

- Tool Kit, General Mechanics, Automotive (Appendix B, Sec. III, item 1)
- Torque Wrench (0-50 Inch-pounds) (Appendix B, Sec. III, item 2)
- Mallet (Appendix B, Sec. III, item 2)

Materials/Parts required:

- Detergent, General Purpose (Item 1, Appendix D)
- Rag, Wiping (Item 2, Appendix D)
- Flange Gasket (2) - X-3702C
- Packing Ring (3) - 235RF-05082P
- Body Gasket - 235RF-05092G
- Coupling Gasket - MS27030

Equipment Condition:

- Water tank empty.

- a. Removal. Disconnect gate valve from water tank filler/discharge assembly.
- b. Disassembly.

NOTE

Disassemble valve only to extent required to accomplish repair.

- (1) Disconnect dust cap (20). Remove eight nuts (25), lockwashers (24), washers (19), bolts (18), and dust cap (20). Separate flanged coupling (17) and gasket (16) from valve body (15).
- (2) Remove gasket (21) from dust cap (20).
- (3) Disconnect dust plug (26). Remove eight nuts (23), lockwashers (22), washers (27), bolts (28), and dust plug (26). Separate flanged coupling (30) and gasket (31) from valve body (15).
- (4) Remove gasket (29) from flanged coupling (30).
- (5) Remove nut (1) and handwheel (2) from stem (10).

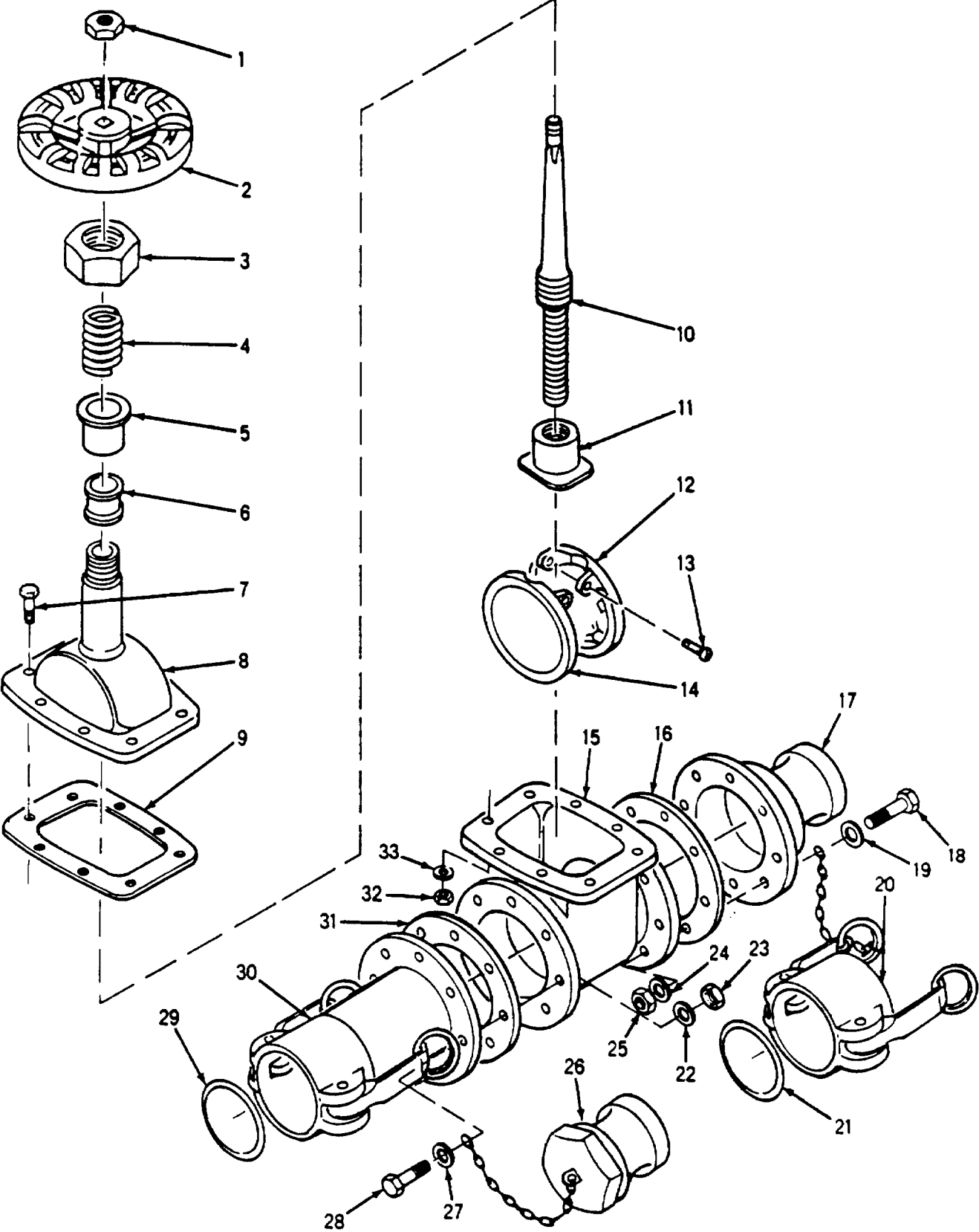

4-19. 4-INCH GATE VALVE MAINTENANCE - cont.

- (6) Remove packing nut (3), gland spring (4), packing ring (5) and packing gland (6).
- (7) Remove eight nuts (32), lockwashers (33), and bolts (7).
- (8) Remove bonnet (8), gasket (9) and attached parts from valve body (15).

NOTE

If needed, tap bonnet (8) with mallet to loosen sealing surfaces.

- (9) Remove two screws (13) and separate discs (12 and 14) from disc riser (11).
- (10) Remove disc riser (11) from stem (10).
- (11) Unscrew stem (10) from bonnet (8) and remove stem.

c. Cleaning.

- (1) Wash all components with clean water and detergent.
- (2) Rinse components in clean water and dry with wiping rag.

d. Inspection.

- (1) Inspect bonnet (8), valve body (15) and flanged couplings (17 and 30) for cracks, scored mating surfaces, stripped threads and corrosion.
- (2) Inspect for bent stem (10). Inspect for galled or stripped threads.
- (3) Inspect sealing surfaces of discs (12 and 14) for deep scratches and cracks.

e. Repair. Replace damaged components. Do not re-use sealing components. Replace all O-rings and gaskets.**f. Assembly.**

- (1) Screw stem (10) into bonnet (8).
- (2) Install disc riser (11) on stem (10).
- (3) Install discs (12 and 14) on riser (11) with two screws (13).
- (4) Turn stem (10) counterclockwise until discs (12 and 14) retract into bonnet (8).
- (5) Position gasket (9) on valve body (15). Guide bonnet (8) and attached parts onto valve body.
- (6) Install eight bolts (7), lockwashers (33) and nuts (32).

- (7) Install packing gland (6), packing ring (5) and gland spring (4) on stem (10). Install packing nut (3).
- (8) Install handwheel (2) and nut (1) on stem (10).

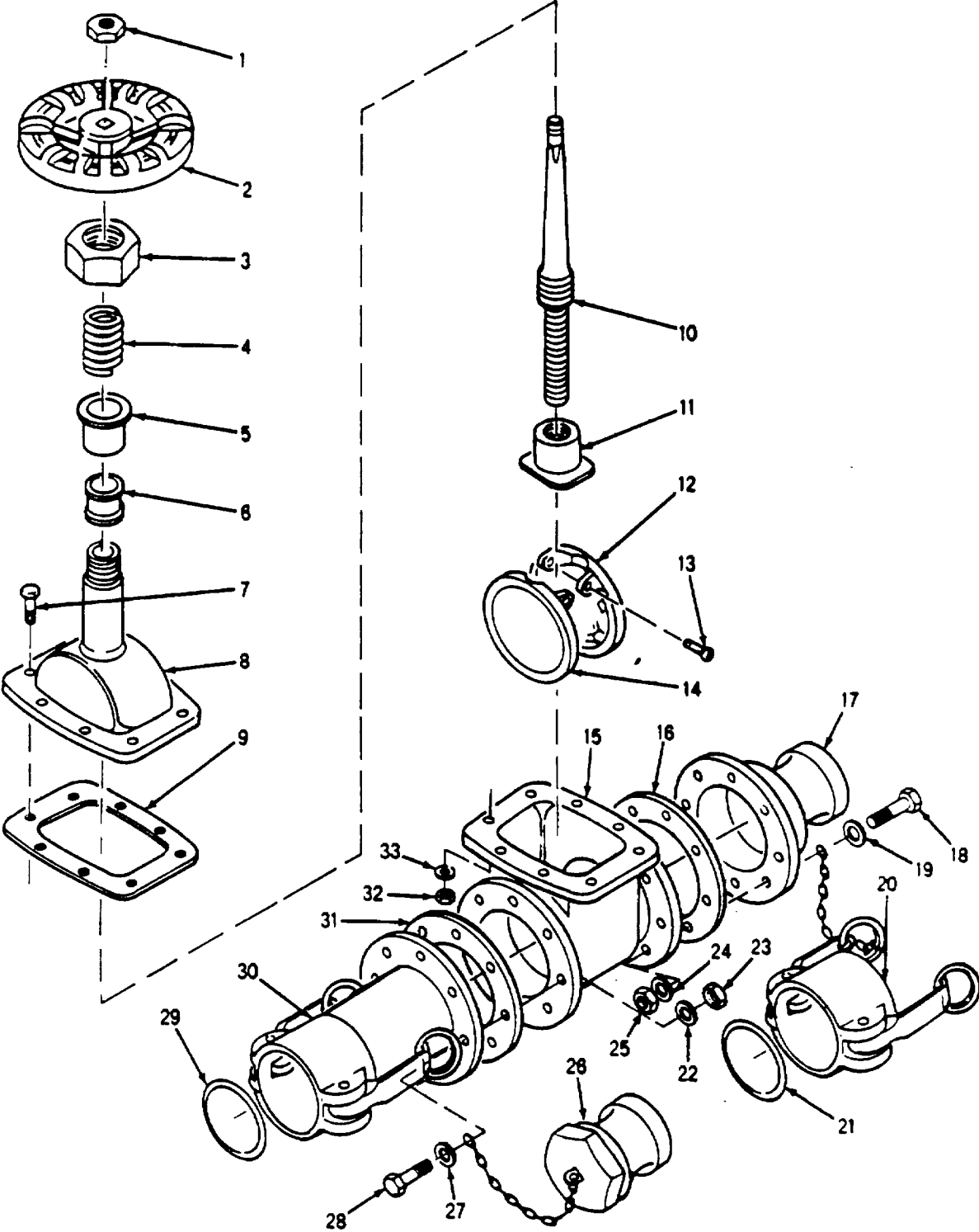

4-19. 4-INCH GATE VALVE MAINTENANCE.

(9) Install gasket (29) in flanged coupling (30).

NOTE

Ensure dust cap and plug chains are positioned at bottom of flanged coupling during assembly.

(10) Position flanged coupling (30) and gasket (31) on valve body (15). Install eight bolts (28), washers (27), lockwashers (22), nuts (23) and dust plug (26).

(11) Position flanged coupling (17) and gasket (16) on body (15). Install eight bolts (18), washers (19), lockwashers (24), nuts (25) and dust cap (20).

g. Installation. Connect gate valve to water tank filler/discharge elbow.

4-20. GROUND CLOTH MAINTENANCE.

Unit maintenance on the ground cloth is limited to replacement. The ground cloth must be replaced when badly torn, frayed or it contains many large punctures.

4-21. REPAIR KIT MAINTENANCE.

Unit maintenance on the repair kit is limited to replacement of missing or damaged components. Inspect sealing clamps for missing plates, gaskets, wing nuts, and bent or stripped threaded rods. Inventory the repair kit to determine if parts are missing.

Section VI. PREPARATION FOR STORAGE OR SHIPMENT

	Page
Removing Equipment from Service.....	4-24
Storage	4-24

4-22. REMOVING EQUIPMENT FROM SERVICE.

To prepare the equipment for storage, perform preparation for movement procedures contained in paragraph 2-10. Make sure all water is removed from water tank, fittings, and accessories.

4-23. STORAGE.

Storage area must protect the equipment from weather extremes. Temperature range for equipment in storage is -25°F to 125°F (-31°C to 51.7°C).

APPENDIX A REFERENCES

A-1. SCOPE.

This appendix lists all forms, field manuals, technical manuals, and miscellaneous publications referenced in this manual.

A-2. FORMS.

Equipment Inspection and Maintenance Worksheet	DA Form 2404
Equipment Control Record	DA Form 2408-9
Recommended Changes to DA Publications	DA Form 2028-2
Recommended Changes to Publications and Blank Forms.....	DA Form 2028
Quality Deficiency Report	SF 368

A-3. FIELD MANUALS.

First Aid for Soldiers.....	FM 21 - 11
-----------------------------	------------

A-4. MISCELLANEOUS.I

Administrative Storage of Equipment	TM 740-90-1
Consolidated Index of Army Publications and Blank Forms	DA PAM 25-30
Destruction of Army Materiel to Prevent Enemy Use.....	TM750-224-3
Unit Repair Parts and Special Tools List for 20,000 and 50,000 Gallon Collapsible Fabric Tank	TM 10-5430-22620P
Operator's, Unit and Direct Support Maintenance Manual for 40,000 Gallon Water Distribution System	TM 10-4610-234-13
The Army Maintenance Management System (TAMMS)	DA PAM 738-750

A-1/(A-2 Blank)

APPENDIX B MAINTENANCE ALLOCATION CHART

Section 1. INTRODUCTION

B-1. GENERAL

a. This section provides a general explanation of all maintenance and repair functions authorized at various maintenance categories.

b. The Maintenance Allocation Chart (MAC) in section II designates overall authority and responsibility for the performance of maintenance functions on the identified end item or component. The application of the maintenance functions to the end item or component will be consistent with the capacities and capabilities of the designated maintenance categories.

c. Section III lists the tools and test equipment (both special tools and common tool sets) required for each maintenance function as referenced from section II.

d. Section IV contains supplemental instructions and explanatory notes for a particular maintenance function.

B-2. MAINTENANCE FUNCTIONS.

Maintenance functions will be limited to and are defined as follows:

a. Inspect. To determine the serviceability of an item by comparing its physical, mechanical, and/or electrical characteristics with established standards through examination (i.e., by sight, sound, or feel).

b. Test. To verify serviceability by measuring the mechanical or electrical characteristics of an item and comparing those characteristics with prescribed standards.

c. Service. Operations required periodically to keep an item in proper operating condition, i.e., to clean (includes decontamination, when required), to preserve, to paint, or to replenish fuel, lubricants, chemical fluids, or gases.

d. Adjust. To maintain or regulate, within prescribed limits, by bringing into proper or exact position, or by setting the operating characteristics to specified parameters.

e. Align. To adjust specified variable elements of an item to bring about optimum or desired performance.

f. Calibrate. To determine and cause corrections to be made or to be adjusted on instruments or test, measuring, and diagnostic equipment used in precision measurement. Consists of comparisons of two instruments, one of which is a certified standard of known accuracy, to detect and adjust any discrepancy in the accuracy of the instrument being compared.

B-2. MAINTENANCE FUNCTIONS (Cont).

g. Remove/Install. To remove and install the same item when required to perform service or other maintenance functions. Install may be the act of emplacing, seating, or fixing into position a spare, repair part, or module (component or assembly) in a manner to allow the proper functioning of an equipment or system.

h. Replace. To remove an unserviceable item and install a serviceable counterpart in its place.

Replace is authorized by the MAC and is shown as the 3rd position code of the SMR code.

i. Repair. The application of maintenance services or other maintenance actions to restore serviceability to an item by correcting specific damage, fault, malfunction, or failure in a part, subassembly, module (component or assembly), end item, or system.

j. Overhaul. That maintenance effort (service/action) prescribed to restore an item to a completely serviceable/operational condition as required by maintenance standards in appropriate technical publications (i.e., DMWR). Overhaul is normally the highest degree of maintenance performed by the Army. Overhaul does not normally return an item to like new condition.

k. Rebuild. Consists of those services/actions necessary for the restoration of unserviceable equipment to a like-new condition in accordance with original manufacturing standards. Rebuild is the highest degree of material maintenance applied to Army equipment. The rebuild operation includes the act of returning to zero those age measurements (hours/miles, etc.) considered in classifying Army equipment and components.

B-3. EXPLANATION OF COLUMNS IN THE MAC, SECTION II

a. Column 1 Group Number. Column 1 lists functional group code numbers, the purpose of which is to identify maintenance significant components, assemblies, subassemblies, and modules with the next higher assembly.

b. Column 2 Component/Assembly. Column 2 contains the names of components, assemblies, subassemblies, and modules for which maintenance is authorized.

c. Column 3 Maintenance Function. Column 3 lists the functions to be performed on the item listed in Column 2. (For detailed explanation of these functions, see paragraph 1-2.)

d. Column 4 Maintenance Category. Column 4 specifies, by the listing of a work time figure in the appropriate subcolumn(s), the category of maintenance authorized to perform the function listed in Column 3. This figure represents the active time required to perform that maintenance function at the indicated category of maintenance. If the number or complexity of the tasks within the listed maintenance function varies at different maintenance categories, appropriate work time figures will be shown for each category. The work time figure represents the average time required to restore an item (assembly, subassembly, component, module, end item, or system) to a serviceable condition under typical field operating conditions. This time includes preparation time (including any necessary disassembly/assembly time), troubleshooting/fault location time, and quality assurance/quality control time in addition to the time required to perform the specific tasks identified for the maintenance functions authorized in the maintenance allocation chart. The symbol designations for the various maintenance categories are as follows:

B-3. EXPLANATION OF COLUMNS IN THE MAC, SECTION II. (Cont)

- C Operator or Crew
- O Unit Maintenance
- F Direct Support Maintenance
- H General Support Maintenance
- D Depot Maintenance

e. Column 5 Tools and Equipment. Column 5 specifies, by code, those common tool sets (not individual tools) and special tools, TMDE, and support equipment required to perform the designated function.

f. Column 6 Remarks. This column shall, when applicable, contain a letter code, in alphabetic order, which shall be keyed to the remarks contained in section IV.

B-4. EXPLANATION OF COLUMNS IN TOOL AND TEST EQUIPMENT REQUIREMENTS, SECTION III.

a. Column 1 Reference Code. The tool and test equipment reference code correlates with a code used in the MAC, section II, column 5.

b. Column 2 Maintenance Category. The lowest category of maintenance authorized to use the tool or test equipment.

c. Column 3 Nomenclature. Name or identification of the tool or test equipment.

d. Column 4 National Stock Number. The National Stock number of the tool or test equipment.

e. Column 5 Tool Number. The manufacturer's part number.

B-5. EXPLANATION OF COLUMNS IN REMARKS, SECTION IV.

a. Column 1 Reference Code. The code recorded in column 6, section II.

b. Column 2 Remarks. This column lists information pertinent to the maintenance function being performed as indicated in the MAC, section II.

Section II. MAINTENANCE ALLOCATION CHART

(1) Group Number	(2) Component/ Assembly	(3) Maint. Function	(4) MAINTENANCE LEVEL					(5) Tools and Ref Code	(6) Remarks
			Unit		Direct Support	General Support	Depot		
			C	O	F	H	D		
00	Tank, Fabric, Collapsible, 20,000 or 50,000 Gallon	Inspect	7	1.0				1 1	A
		Replace		2.5					
		Repair	3	4.0					
01	Water Tank	Inspect	.2						A
		Replace		1.0					
		Repair	.3						
02	Fitting Assemblies								
0201	Vent Fitting Assembly	Inspect	.1					1,2 1,2	
		Replace		0.5					
		Repair		1.0					
0202	Filler/Discharge Assembly	Inspect	.1					1,2 1,2	B
		Replace		0.5					
		Repair		1.0					
0203	Drain Fitting Assembly	Inspect	.1					1,2 1,2	B
		Replace		0.5					
		Repair		1.0					
03	Accessories								
0301	Drain Hose Assembly	Inspect	.1						
		Replace		0.3					
0302	Valve,Gate,4-inch	Inspect	.1					1 1, 2	B
		Replace		0.1					
		Repair		1.0					
04	Ground Cloth	Inspect	1						
		Replace		0.1					
05	Repair Kit	Inspect	1						
		Replace		0.1					

Section III. TOOLS AND TEST EQUIPMENT REQUIREMENTS

(1) Reference Code	(2) Maintenance Category	(3) Nomenclature	(4) National/ NATO Stock Number	(5) Tool Numbers
1	O	Tool Kit, General Mechanics	5180-00-177-7033	SC-5180-90-CL-N26
2	O	Shop Equipment, Automotive Vehicle	4910-00-754-0654	SC-4910-95-CL-A72

Section IV. REMARKS

Reference Code	Remarks
A	Crew level repair limited to installation of clamp patches.
B	Repair limited to replacement of defective components.

B-5/(B-6 Blank)

APPENDIX C

COMPONENTS OF END ITEM AND BASIC ISSUE ITEMS LIST

Section I. INTRODUCTION

C-1. SCOPE

This appendix lists components of end item and basic issue items for the 20K and 50K water tanks to help you inventory items required for safe and efficient operation.

C-2. GENERAL

The Components of End Item and Basic Issue Items List are divided into the following sections:

- a. Section II, Components of End Item. This listing is for informational purposes only, and is not authority to requisition replacements. These items are part of the end item, but are removed and separately packaged for transportation or shipment. As part of the end item, these items must be with the end item whenever it is issued or transferred between property accounts. Illustrations are furnished to assist you in identifying the items.
- b. Section III, Basic Issue Items. These are the minimum essential items required to place the 20K or 50K water tank in operation, to operate it, and to perform emergency repairs. Although shipped separately packaged, BII must be with the 20K or 50K water tank during operation and whenever it is transferred between property accounts. The illustrations will assist you with hard to identify items. This manual is your authority to request/requisition replacement BII, based on TOE/MTOE authorization of the end item.

C-3. EXPLANATION OF COLUMNS

The following provides an explanation of columns found in the tabular listing:

- a. Column (1) Illustration Number (Illus Number). This column indicates the number of the illustration in which the item is shown.
- b. Column (2) National Stock Number. Indicates the national stock number assigned to the item and will be used for requisitioning purposes.
- c. Column (3) Description and Usable on Code. Identifies the Federal item name (all in capital letters) followed by a minimum description when needed. The last line below the description is the Commercial and Government Entity Code (CAGEC) (in parentheses) and the part number. If the item you need is not the same for different models of the equipment, a Usable on Code on the right side of the description column is on the same line as the part number. These codes are identified below:

<u>CODE</u>	<u>USED ON</u>
ETQ	Bell-Avon 20K
FLP	Amfuel 20K
FLQ	Amfuel 50K

- d. Column (4) Unit of Measure (U/M). Indicates the measure used in performing the actual operational/maintenance function. This measure is expressed by a two character alphabetical abbreviation (e.g., ea., in, pr).
- e. Column (5) Quantity required (Qty rqd). Indicates the quantity of the item authorized to be used with/on the equipment

Section II. COMPONENTS OF END ITEM

(1) Illus Number	(2) National Stock Number	(3) Description CAGEC and Part Number	Usable on Code	(4) U/M	(5) Qty Rqd
1		DRAIN HOSE ASSEMBLY (80691) BA89086	ETQ	EA	1
1.1		DRAIN HOSE ASSEMBLY (81348) ZZ-H-601-3-2-32-008	FLP, FLQ	EA	1
2		ELBOW, QUICK DISCONNECT, 90 DEG, 4-IN FEMALE X FEMALE (80691) 40BB90AL		EA	1
3		ELBOW, QUICK DISCONNECT, 90 DEG, 4-IN FEMALE X MALE (80691) 40BA90AL		EA	1
4		FITTING ASSEMBLY, VENT REFBR TO I.GURE 2 IN Th 10-5430-226-20P		EA	1
5	5330-00-064-2072	GASKET, 4-INCH FLANGE (81718) C2479M		EA	2
6	5330-00-612-2414	GASKET, QUICK DISCONNECT COUPLING (96906) MS27030-6		EA	2
7	5330-00-899-4509	GASKET, QUICK DISCONNECT COUPLING (96906) MS27030-9		EA	2
8		GATE VALVE ASSEMBLY 4-INCH (41592) 235AF-O500AV		EA	1
9	4820-00-595-1842	GATE VALVE, 1/2-INCH (76364) 1148-1/2	ETQ	EA	1
9.1		BALL VALVE, 2-INCH (57661) 82-108	FLP, FLQ	EA	1
10		GROUND CLOTH (66618) X-3619B	ETQ, FLP	EA	1
		GROUND CLOTH (05476) 80393	FLQ	EA	1
11	5330-00-250-0224	PACKING, PREFORMED (96906) MS29513-250		EA	2
12	5330-00-364-9862	PACKING, PREFORMED (96906) MS9021-381		EA	2
13	5430-00641-8957	REPAIR KIT (81349) MIL-R-22368		EA	1
14		TANK, FABRIC, COLLAPSIBLE, 20K (66618) BA88-028	ETQ	EA	1
		TANK, FABRIC, COLLAPSIBLE, 20K (05476) 91011	FLP	EA	1
		TANK, FABRIC, COLLAPSIBLE, 50K (05476) 91005-1	FLQ	EA	1

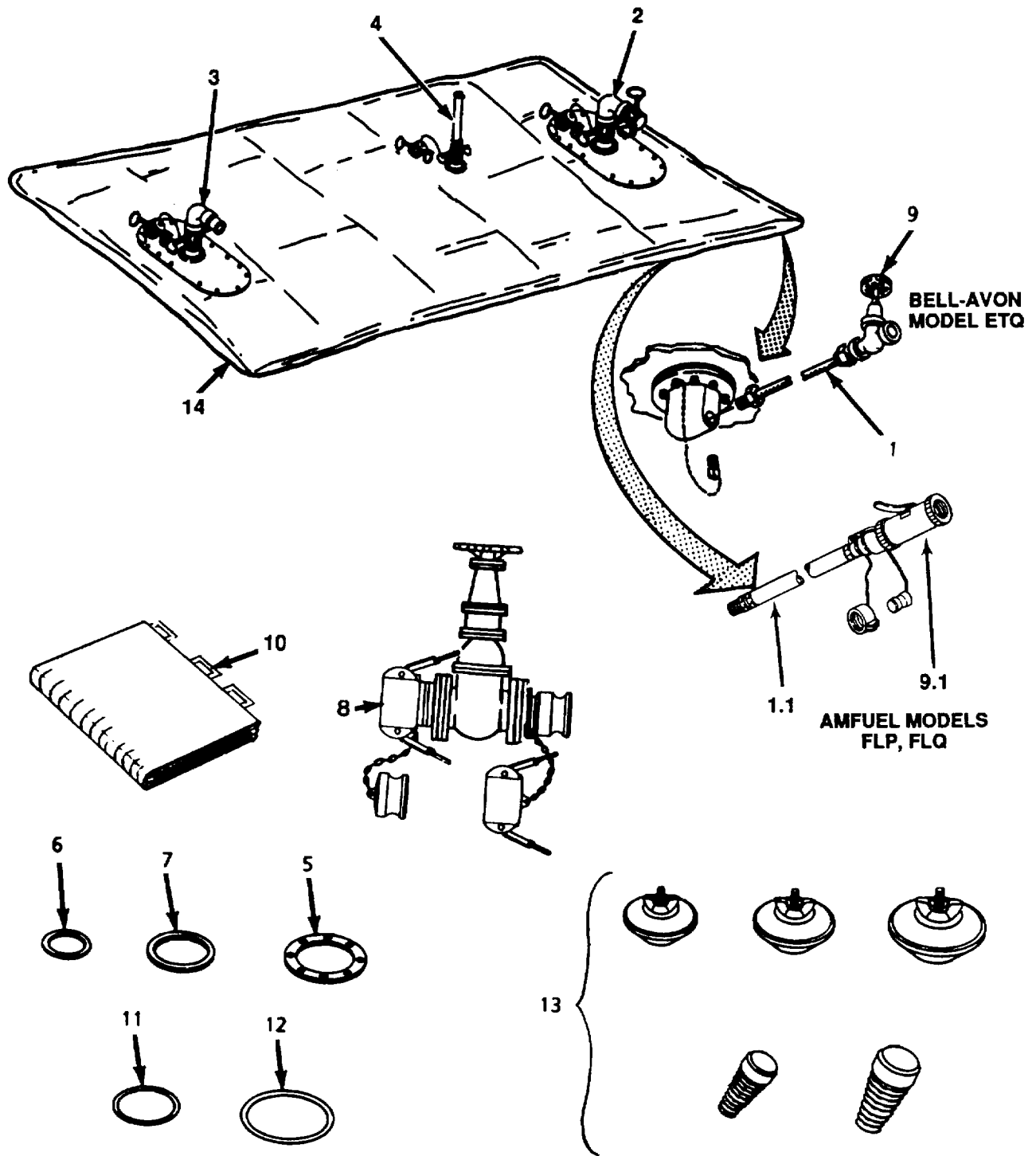

Section III. BASIC ISSUE ITEMS

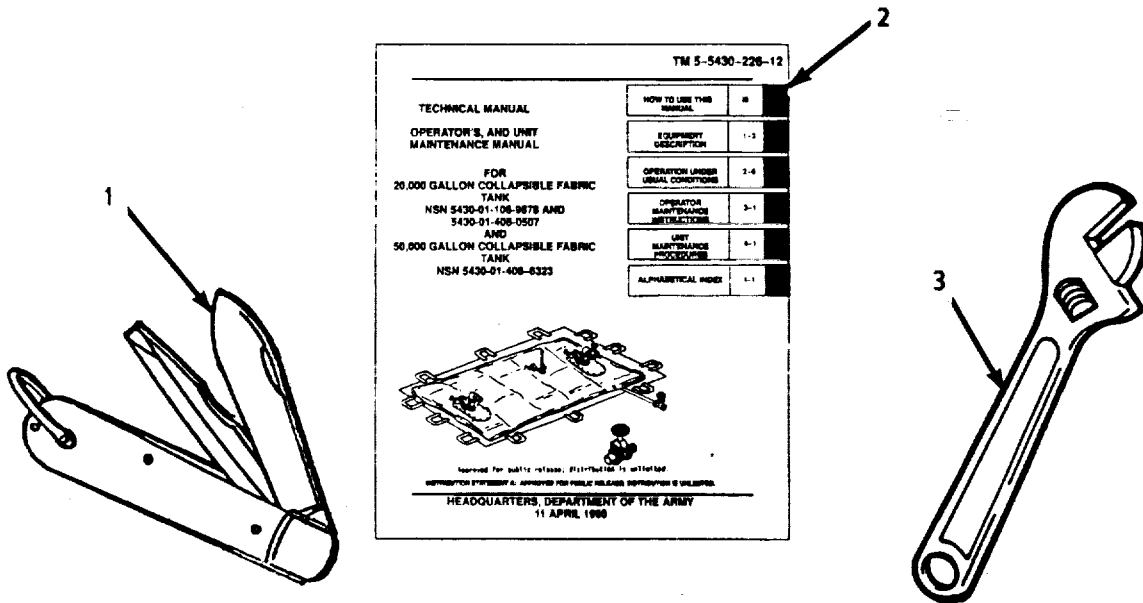

(1) Illus Number	(2) National Stock Number	(3) Description CAGEC and Part Number	Usable on Code	(4) U/M	(5) Qty Rqd
1	5110-00-162-2205	KNIFE, POCKET (81349) MIL-K-818C		EA	1
2		TECHNICAL MANUAL, OPERATOR'S AND UNIT MAINTENANCE FOR 20,000 AND 50,000 GALLON COLLAPSIBLE FABRIC TANKS, TM 5-5430-226-12.		EA	1
3	5120-00-240-5336	WRENCH, ADJUSTABLE, 12" (80244) GGG-W-631 TY3SZ12		EA	1

APPENDIX D**EXPENDABLE/DURABLE SUPPLIES AND MATERIALS LIST**

Section I. INTRODUCTION**D-1. SCOPE**

This appendix lists expendable/durable supplies and materials you will need to operate and maintain the 20K or 50K water tanks. These items are authorized to you by CTA 50-970, Expendable/Durable Items (except Medical, Class V, Repair Parts and Heraldic Items), or CTA 8-100, Army Medical Department Expendable/Durable Items.

D-2. EXPLANATION OF COLUMNS

a. Column 1 Item Number. This number is assigned to the entry in the listing and is referenced in the narrative instructions to identify the material (e.g., "Use wiping rag, Item 12, Appendix D").

b. Column 2 Category. This column identified the lowest category of maintenance that required the listed item:

- C - Operator/Crew
- O - Unit Maintenance

c. Column 3 - National Stock Number. This is the national stock number assigned to the item; use it to request or requisition the items.

d. Column 4 - Description. Indicates the federal item name and, if required, a description to identify the item. The last line for each item indicates the part number followed by the Commercial And Government Entity (CAGE) code in parentheses, if applicable.

e. Column 5 - Unit of Measure (U/M). Indicates the measure used in performing the actual maintenance function. This measure is expressed by a two character alphabetical abbreviation (e.g., ea., in, pr). If the unit of measure differs from the rest of the issue, requisition the lowest unit of issue that will satisfy your requirements.

Section II. EXPENDABLE/DURABLE SUPPLIES AND MATERIALS LIST

(1) Item No.	(2) Category	(3) National Stock Number	(4) Description	(5) U/M
1	O	7930-00-985-6911	DETERGENT, GENERAL PURPOSE (81349) MIL-D-16791	5GL
2	C	7920-00-205-1711	RAG, WIPING (58536) A-A-531	BL
3	C	8030-00-889-3535	TAPE, ANTI-SEIZE (80244) MIL-T-27730SZ2	RL

APPENDIX E
ADDITIONAL AUTHORIZATION LIST (AAL)

NOT APPLICABLE

E-1/(E-2 Blank)

INDEX

Paragraph	Page
-A-	
Abbreviations, List of	1-2
Adjustments, Initial	2-6
Assembly	
Drain Fitting Assembly	4-18
Filler/Discharge Assembly	4-16
Gate Valve (4-Inch)	4-24
Vent Fitting Assembly, Cam-lock Style	4-11
Vent Fitting Assembly, Welded Base Style	4-13
Assembly and Preparation for Use	
Assembly	2-7
Site Selection	2-6
Unfolding	2-6
-C-	
Checking Unpacked Equipment	4-2
Cleaning	
Drain Fitting Assembly	4-18
Filler/Discharge Assembly	4-16
Gate Valve (4-Inch)	4-24
Vent Fitting Assembly, Cam-lock Style	4-11
Vent Fitting Assembly, Welded Base Style	4-12
Collapsible Fabric Tank Maintenance	4-8
Common Tools and Equipment	4-1
Control Valves	2-1
-D-	
Data, Equipment	1-6
Decals and Instruction Plates	2-17
Destruction of Army Materiel to Prevent Enemy Use	1-2
Differences Between Models	1-3
Disassembly	
Filler/Discharge Assembly	4-14
Gate Valve (4-Inch)	4-22
Vent Fitting Assembly, Cam-lock Style	4-9
Vent Fitting Assembly, Welded Base Style	4-12
Discharge Mode	2-11
Drain Fitting Assembly Maintenance	4-18

INDEX

Paragraph	Page
Drain Hose Assembly Maintenance	4-20
Drain Mode	2-12
-E-	
Equipment Characteristics, Capabilities and Features	
Characteristics	1-3
Capabilities and Features	1-3
Equipment Data	1-6
-F-	
Fill Mode	2-10
Filler/Discharge Assembly Maintenance	4-14
Forms and Records, Maintenance	1-1
Gate Valve, 4-Inch, Maintenance	4-22
Ground Cloth Maintenance	4-26
-H-	
Hand Receipt Manuals	1-1
Handling, Care and Safety	1-9
How to Use This Manual	iii
-I-	
Initial Adjustment	2-6
Inspection	
Drain Fitting Assembly	4-18
Filler/Discharge Assembly	4-16
Gate Valve (4-Inch)	4-24
Vent Fitting Assembly, Cam-lock Style	4-11
Vent Fitting Assembly, Welded Base Style	4-12
Installation	
Drain Fitting Assembly	4-19
Drain Hose Assembly	4-20
Filler/Discharge Assembly	4-16
Gate Valve (4-Inch)	4-26
Vent Fitting Assembly, Cam-lock Style	4-11
Vent Fitting Assembly, Welded Base Style	4-13

INDEX

Paragraph	Page
-L-	
List of Abbreviations	1-2
Location and Description of Major Components	
Accessories	14
Fitting Assemblies	14
Ground Cloth	14
Repair Kit	14
Tank 14	
-M-	
Maintenance Forms and Records	1-1
Maintenance Procedures	
Drain Fitting Assembly	4-18
Drain Hose Assembly	4-20
Filler/Discharge Assembly	4-14
Gate Valve (4-Inch)	4-22
Ground Cloth	4-26
Repair Kit	4-26
Vent Fitting Assembly, Cam-lock Style	4-9
Vent Fitting Assembly, Welded Base Style	4-12
Major Components, Location and Description.....	1-4
Manuals, Hand Receipt	1-1
Models, Differences Between	1-3
-O-	
Operation	
Discharge Mode	2-11
Fill Mode	2-10
Operation in Dusty or Sandy Areas	2-18
Operation in Extreme Cold	2-18
Operation in Extreme Heat	2-18
Operation, Principles of	1-9
Operator Preventive Maintenance Checks and Services (PMCS)	2-3
Operator's Controls and Indicators	2-1
Control Valves	2-1

INDEX

Paragraph	Page
-P-	
PMCS, Operator	2-3
PMCS, Unit	4-3
Preparation for Movement	
Disassembly	2-12
Folding	
2-15	
Packing	2-16
Preparation for Storage or Shipment	
Removing Equipment From Service	4-26
Storage	4-26
Principles of Operation	1-9
-R-	
Removal	
Drain Fitting Assembly	4-18
Drain Hose Assembly	4-20
Filler/Discharge Assembly	4-14
Gate Valve (4-Inch)	4-22
Vent Fitting Assembly, Cam-lock Style	4-9
Vent Fitting Assembly, Welded Base Style	4-12
Removing Equipment from Service	4-26
Repair	
Drain Fitting Assembly	4-19
Filler/Discharge Assembly	4-16
Gate Valve (4-Inch)	4-24
Vent Fitting Assembly, Cam-lock Style	4-11
Vent Fitting Assembly, Welded Base Style	4-13
Repair Kit	4-26
Repair Parts	4-1
Reporting Equipment Improvement Recommendations (EIR's)	1-2
-S-	
Safety, Care, and Handling	1-9
Scope	1-1
Service Upon Receipt	
Checking Unpacked Equipment	4-2
Site Selection	4-2
Unpacking	4-2

INDEX

Paragraph	Page
Site Selection	2-6,4-2
Special Tools, TMDE, and Support Equipment	4-1
Storage	4-26
Storage or Shipment, Preparation for	1-2
Troubleshooting (Operator)	3-1
Troubleshooting (Unit)	4-5
-U-	
Unfolding	2-6
Unit Preventive Maintenance Checks and Services	4-3
Unit Troubleshooting Procedures	4-5
Unpacking	4-2
-V-	
Vent Fitting Assembly Maintenance	
Cam-lock Style	4-9
Weld Base Style	4-12
-W-	
Water Tank Maintenance	4-8
Water Tank Repair (Operator)	3-3

By Order of the Secretary of the Army:

DENNIS J. REIMER
General, United States Army
Chief of Staff

Official:

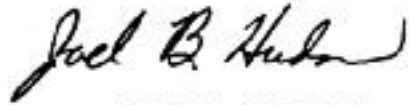

JOEL B. HUDSON
Administrative Assistant to the
Secretary of the Army
03179

DISTRIBUTION:

To be distributed in accordance with DA Form 12-25-E, block no. 5480, requirements for TM 5-5430-226-12.

These are the instructions for sending an electronic 2028

The following format must be used if submitting an electronic 2028. The subject line must be exactly the same and all fields must be included; however only the following fields are mandatory: 1, 3, 4, 5, 6, 7, 8, 9, 10, 13, 15, 16, 17, and 27.

From: "Whomever" <whomever@avma27.army. mil>
To: mpmtavma28@st-louis-emh7.army. mil

Subject: DA Form 2028

1. **From:** Joe Smith
2. Unit: home
3. **Address:** 4300 Park
4. **City:** Hometown
5. **St:** MO
6. **Zip:** 77777
7. **Date Sent:** 19-OCT-93
8. **Pub no:** 55-2840-229-23
9. **Pub Title:** TM
10. **Publication Date:** 04-JUL-85
11. Change Number: 7
12. Submitter Rank: MSG
13. **Submitter FName:** Joe
14. Submitter MName: T
15. **Submitter LName:** Smith
16. **Submitter Phone:** 123-123-1234
17. **Problem: 1**
18. Page: 2
19. Paragraph: 3
20. Line: 4
21. NSN: 5
22. Reference: 6
23. Figure: 7
24. Table: 8
25. Item: 9
26. Total: 123
27. **Text:**

This is the text for the problem below line 27.

RECOMMENDED CHANGES TO EQUIPMENT TECHNICAL PUBLICATIONS

 <div style="border: 1px solid black; border-radius: 15px; padding: 5px; display: inline-block; margin-left: 20px;"> <p style="font-size: small; margin: 0;">THEN...JOT DOWN THE DOPE ABOUT IT ON THIS FORM. CAREFULLY TEAR IT OUT, FOLD IT AND DROP IT IN THE MAIL.</p> </div>		SOMETHING WRONG WITH PUBLICATION	
		FROM: (PRINT YOUR UNIT'S COMPLETE ADDRESS)	
PUBLICATION NUMBER		DATE SENT	
PUBLICATION DATE		PUBLICATION TITLE	
IN THIS SPACE, TELL WHAT IS WRONG AND WHAT SHOULD BE DONE ABOUT IT.			
BE EXACT PIN-POINT WHERE IT IS			
PAGE NO.	PARA-GRAPH	FIGURE NO.	TABLE NO.
PRINTED NAME, GRADE OR TITLE AND TELEPHONE NUMBER		SIGN HERE	

